

Transient Voltage Suppressor

Part Number 02-331969

General Description

The Vickers Transient Voltage Suppressor (TVS) accessory is available for the purpose of improving the life of proportional valves with integrated control electronics in applications exposed to potentially destructive levels of ambient electromagnetic radiation, or where interconnecting wiring contain excessive voltage spikes.

Application

Most applications do not require transient voltage suppression devices. Implementation of best wiring practices which include; proper wire routing, isolation from noisy AC and inductive solenoid wiring, combined with proper grounding and shielding, significantly effect the survivability of any electronic circuit in harsh electromagnetic environments. There are, however, severe cases or applications where transient voltage spikes are present on the control or power supply lines. In either case, installation of a transient voltage suppression device (TVS) can significantly improve the life of connected equipment.

Protection

The Vickers Transient Voltage Suppressor (TVS) accessory is designed to prevent excessively high voltage spikes from reaching the valve mounted control electronics by connecting all six valve interface connector pins through TranZorbs™ to protective ground (pin G and the case, see figure 2).

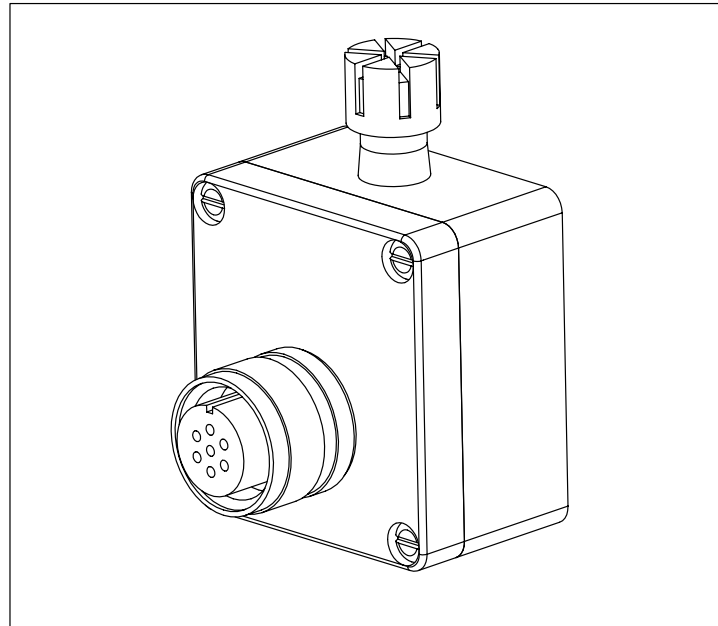

No power is drawn by the TVS unit under normal operating conditions. The TranZorbs only conduct when excessively high voltages are present, effectively quenching very short duration voltage spikes. The external earth terminal on the box must be connected to an efficient earth ground for maximum benefit.

The level of protection is implicit in the specifications of the component parts, which are fully detailed in the circuit diagram (figure 2). Clearly the level of protection is limited, and may not be adequate in extreme situations.

Limitations

The Vickers TVS is, by design, a **transient** voltage suppressor. Static voltages applied to any pin, which exceed the Vickers proportional valve maximum interface voltage ratings, may damage the TVS, and the valve electronics as well

Refer to Transorb manufacturer's specifications for duty cycle, and power limitations for components listed in (figure 2).

Installation

The Vickers Transient Voltage Suppressor (TVS) accessory is plug compatible with Vickers "KA" and proportional valves with integrated electronics. Male and female 7-pin bulkhead connectors on the TVS allow the unit to be fitted between the application interface cable and the 7-pin connector directly on the proportional valve itself as shown in (figure 1). It is important to locate the TVS as close to the valve as possible. For this reason, the TVS should always be mounted as specified. Installation requires no tools, or any changes to the existing wiring, only the addition of a ground lead. Refer to (figure 3) for package dimensions.

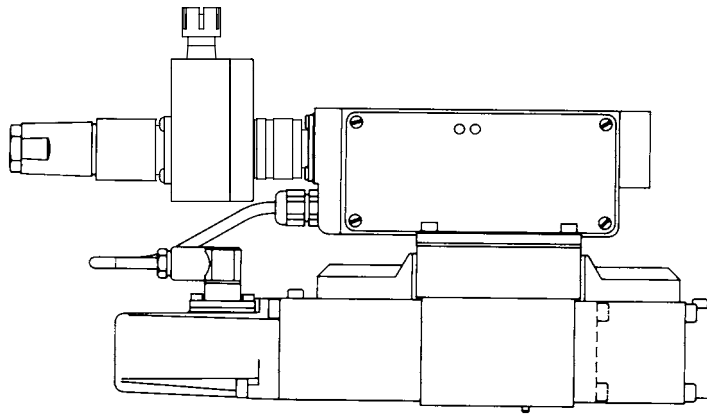
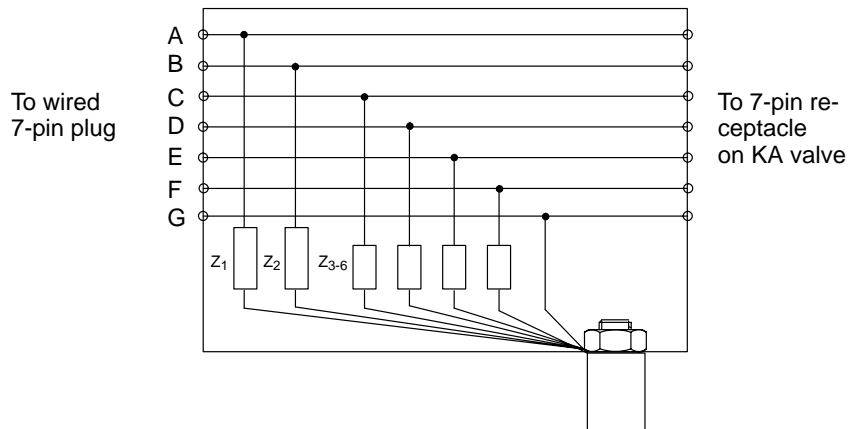

Figure 1: Transient Voltage Suppressor mounted on KAFDG4V-3



Note: the earth ground connection must be connected to an efficient earth ground.

Figure 2: Circuit diagram – Transient Voltage Suppressor

