



EFX 1612J Electronic Controller

Programmed with Eaton CONTROL F(x)TM to IEC 61131-3 Standard

2nd CAN interface for gateway function according to SAE J 1939

Supply voltage 10...32V DC

TECHNICAL DATA	CONTROLLER FOR THE IMPLEMENTATION OF A CENTRAL OR DECENTRALIZED ELECTRO-HYDRAULIC SYSTEM
Housing	closed screened metal housing with flange fastening
Dimensions (H x W x D)	153 x 132 x 43 mm
Mounting	by means of 4 M5 x L screws to DIN 7500 or DIN 7984 mounting position horizontal or vertical to the mounting wall
Connection	55-pin connector, latched, protected against reverse polarity type AMP housing or Framatome AMP junior timer contacts, crimp connection 0.5/2.5 mm ²
Weight	0.95 kg
Inputs	8
can be configured as	4 digital; for positive sensor signals (Low Side); NAMUR; with diagnostic capability incl. 2 pulse inputs (max. 50 kHz) 4 analog; 0...10/32 V DC or 0/4...20 mA
Outputs	4
can be configured as	digital, positive switching (High Side) PWM (PWM frequency 20...250 Hz) current-controlled (0.1...4 A)
Switching current per output	max. 4 A
Total current of all outputs	max. 16 A
Operating voltage UB	10...30 V DC
Oversvoltage	36 V for t ≤ 10 s
Reset in case of undervoltage	at UB ≤ 9.5 V
Auto save	at UB ≤ 9.0 V
Current consumption	≤ 160 mA (without external load)
Housing temperature	- 40...85 °C (depending on the load)
Storage temperature	- 40...85 °C
Protection	IP 67 (for inserted plug with individually sealed cores e.g. ECEFX16 12S)
CAN interface 1	CAN interface 2.0 B, ISO 11898
Baud rate	50 Kbits/s...1 Mbits/s (default setting 125 kBits/s)
Communication profile	CANopen, CiA DS 301 version 3.0, CiA DS 401 version 1.4
CAN interface 2	CAN interface 2.0 A/B, ISO 11898
Baud rate	50 Kbits/s...500 Kbits/s (default setting 125 kBits/s)
Communication profile	SAE J 1939
Serial interface	RS 232 C
Baud rate	9.6 Kbits/s, 19.2 Kbits/s, 28.8 Kbits/s
Topology	point-to-point (max. 2 participants); master/slave connection
Protocol	predefined protocol (INTELHEX)
Node ID (default)	hex 20 (= dec. 32)

EFX1612J**Technical data**

Processor	CMOS microcontroller 16 bits C167C, pulse frequency 20 MHz
Device monitoring	undervoltage monitoring, watchdog function, check sum test for program, and system monitoring for excess temperature
Program memory	192 Kbytes flash, can be used by the user
Data memory	64 Kbytes SRAM, 32 Kbytes flash, 3 Kbytes EEPROM
Data memory (protected in case of power failure)	256 bytes (auto save memory)
Status LED	two-colour LED (red/green)

Operating status (status LED)

During the start-up or reset of the controller the green and red LEDs light simultaneously. This appears orange.

LED Color	Status	Description
–	constantly off	no supply voltage
orange	for a short time on	initialisation or reset checks
green	5 Hz	no operating system loaded
green	2.0 Hz constantly on	Run Stop
red	2.0 Hz constantly on	Run with error Fatal error or stop with error

Electrical connection

To guarantee the electrical interference protection of the controller, the housing must be connected to the ground of the vehicle!

Designation	Pin no.	Potential
supply voltage	23	10...32 V DC (V_{BB_s})
supply voltage outputs	05	10...32 V DC (V_{BB_o})
ground	01	GND_s
CAN interface 1	14 / 51 32 / 50 33 / 15	CAN_H CAN_L CAN_GND
CAN interface 2	42 / 43 44 / 45 26 / 31	CAN_H CAN_L CAN_GND
RS 232 interface (programming)	07 (TxD) 06 (RxD) 13 (GND)	pin 02, PC D-Sub (9 pins) pin 03, PC D-Sub (9 pins) pin 05, PC D-Sub (9 pins)
“TEST” input programming mode operating mode	24 24	10...32 V DC (V_{BB_s}) open

EFX 1612J**Characteristics of the inputs/outputs****Digital inputs**

(%IX0.0 / 0.8 / 1.0 / 1.8)
can be configured as ...

■ Digital inputs for positive switching sensor signals

switch-on level 0.7 U_B
switch-off level 0.4 U_B
input resistance 2.86 kΩ
input frequency 50 Hz

■ NAMUR inputs; digital inputs with diagnostic capability when used with ifm NAMUR sensors, supply voltage 5...25 V,

input resistance 2.86 kΩ
input frequency 50 Hz

■ Diagnostic inputs (analog evaluation), digital inputs with diagnostic capability when an external resistor connection is used, corresponds to the NAMUR input

input resistance 2.86 kΩ
input frequency 50 Hz

■ Frequency inputs; with diagnostic capability, evaluation with integrated comparator is used, corresponds to the

input frequency 1 100 Hz...50 kHz (IN 0)
input frequency 2 100 Hz...50 kHz (IN 1)
input resistance 2.86 kΩ

Analog inputs

(%IW6...%IW9)
can be configured as ...

■ Voltage inputs

input voltage 0...10/32 V
resolution 10 bit
input resistance 50 kΩ
input frequency 50 Hz

■ Current inputs

input current 0/4...20 mA
resolution 10 bit
input resistance 400 Ω
input frequency 50 Hz

Outputs

(%QX0.0 / 0.8 / 1.0 / 1.8)
can be configured as ...

■ Semi conductor outputs, positive switching (high side), short-circuit and overload protected

switching voltage 10...32 V DC
switching current max. 4 A; total current max. 16 A

■ PWM outputs; with diagnostic capability

PWM frequency max. 250 Hz
PWM pulse ratio 1...99 %
resolution depending on the PWM frequency
switching current max. 4 A; total current max. 16 A
integrated pull-down resistor (4.7 kΩ)

■ Current-controlled outputs; with diagnostic capability

switching current 0.1...4 A; total current max. 16 A
setting resolution 1 mA
control resolution 5 mA
accuracy ± 2% FS

Input "TEST"

During the test mode (e.g. programming) the "TEST" connection must be connected to UB. For the "RUN" mode the input must not be connected.

input resistance 12 kΩ

Characteristics of the inputs/outputs

Humidity test to IEC 68-2-30

≤ 90 % rel. humidity, non-condensing

Mechanical resistance

vibration to IEC 68-2-6, shock to IEC 68-2-27, bump to IEC 68-2-29

Immunity to conducted interference

to DIN 40839/part 1, pulses 1, 2, 3a, 3b (corresponds to ISO 7637) severity level 4, function state C, A
to DIN 40839/part 1, pulses 5 (corresponds to ISO 7637) severity level 1, function state C
to DIN 40839/part 3, pulses 1, 2, 3a, 3b (corresponds to ISO 7637) severity level 4, function state A

EC declaration of conformity
Immunity to interfering fields
Interference emission

according to directive EMC 89/336/EEC and LV 73/23/EEC
to EN 61000-6-2: 2001, at 100 V/m
to EN 61000-6-4: 2001

e1 type approval

according to directive 72/245/EWG, supplemented by directive 2006/28/EG

Railway specification

according to guideline BN 411 002 (DIN EN 50155, part 10.2)

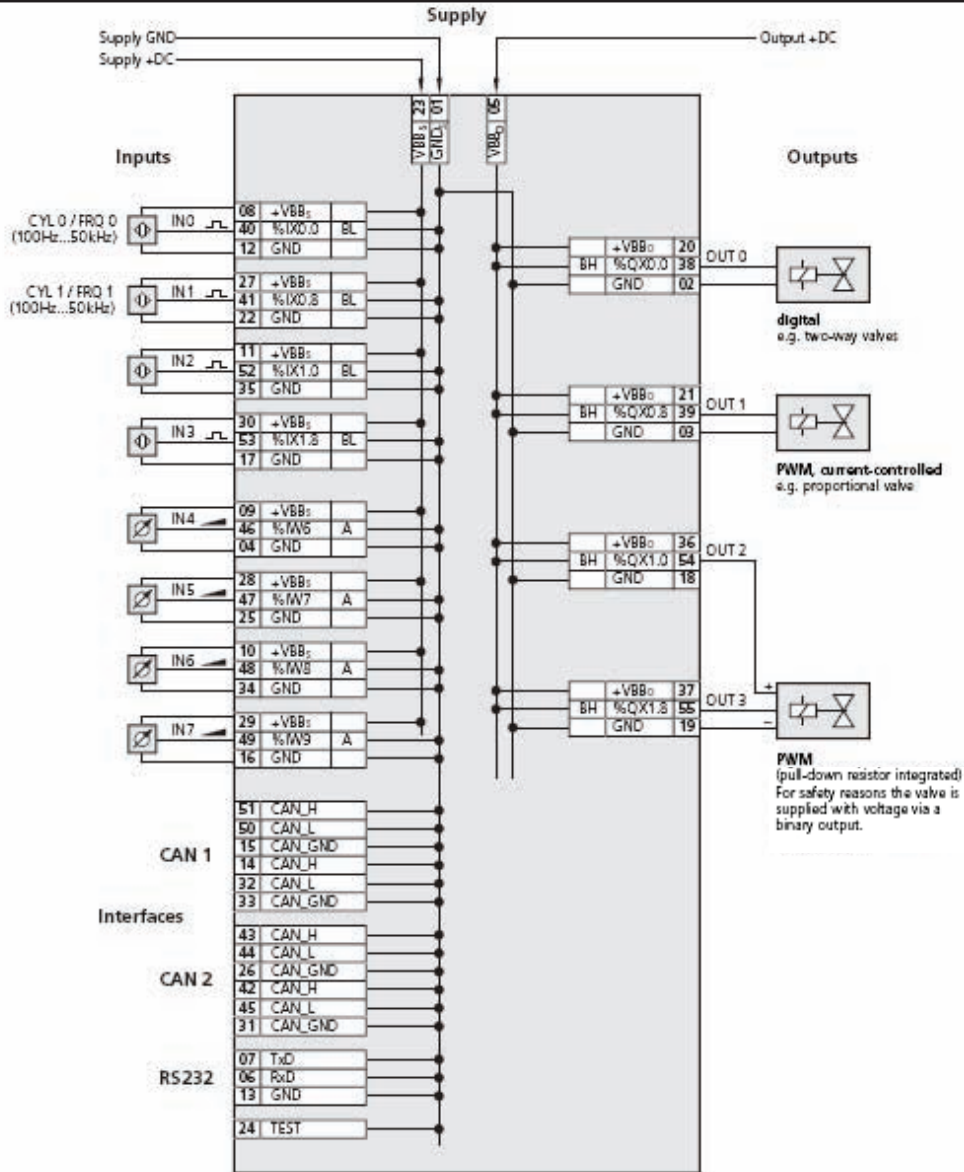

Explanation of the abbreviations:

A = analog
 BH = binary high side
 BL = binary low side
 CAN_H = CAN interface

CAN_L = CAN interface
 CYL = inputs for time period measurement
 FRQ = frequency inputs
 PWM = pulse-width-modulated signals

RxD = serial interface (data received)
 TxD = serial interface (data transmitted)
 VBB₀ = supply voltage outputs
 VBB_s = supply voltage sensors/module

%IWx = IEC address for analog input
 %IX0.xx = IEC address for binary input
 %QX0.xx = IEC address for binary output

Eaton

Hydraulics Operations USA
 14615 Lone Oak Road
 Eden Prairie, MN 55344
 USA
 Tel: 952-937-9800
 Fax: 952-294-7722
 www.hydraulics.eaton.com

Eaton

Hydraulics Operations Europe
 Route de la Longeraie 7
 1110 Morges
 Switzerland
 Tel: +41 (0) 21 811 4600
 Fax: +41 (0) 21 811 4601

Eaton

Hydraulic Operations Asia Pacific
 11th Floor Hong Kong New World Tower
 300 Huaihai Zhong Road
 Shanghai 200021
 China
 Tel: 86-21-6387-9988
 Fax: 86-21-6335-3912

