

The Eaton logo is displayed in white, bold, sans-serif capital letters. The letter 'A' is stylized with a triangle pointing upwards. The logo is positioned in the upper left quadrant of the image, overlaid on a blue rectangular background that also contains the text below it.

CAN-Enabled Electronic
Displacement Control



Table of Contents

CAN-Enabled Electronic Displacement Control for Series 2 Pumps	3
System Interconnect Diagram	4
Product Application Guide	4
CAN EDC and Pump Control Selection	5
Pump Displacement Command Structure	6
Installment Requirements	7
Connector	8
Graphical User Interface	9
Graphical User Interface Interconnect Diagram	10
CAN EDC Specifications	11

Information contained in this document is subject to change without notice. Performance values are typical values. Customers are responsible for selecting products for their applications using normal engineering methods.

General

Eaton Corporation is a diversified industrial manufacturer with 2005 sales of \$11.1 billion. Eaton is a global leader in electrical systems and components for power quality, distribution and control; fluid power systems and services for industrial, mobile and aircraft equipment; intelligent truck drivetrain systems for safety and fuel economy; and automotive engine air management systems, power train solutions and specialty controls for performance, fuel economy and safety.

Eaton has 60,000 employees and sells products to customers in more than 125 countries.

Eaton Corporation is a global diversified industrial manufacturer. Eaton is a leader in:

- Fluid power systems
- Electrical power quality, distribution and control
- Automotive engine air management and fuel economy
- Intelligent truck systems for fuel economy and safety

For more information, visit www.eaton.com.

World Class Brands, Products and Systems



Aeroquip



Boston



Char-Lynn



Hydro-Line



Vickers



Weatherhead

CAN-Enabled Electronic Displacement Control

Eaton's CAN Enabled Electronic Displacement Control (EDC) for the Series 2 pumps offers best-in-class electro-hydraulic control for mobile closed circuit pump applications. This high level of performance is achieved by a unique combination of a microprocessor-based intelligent control and an electro-proportional pump control that utilizes electronic pump swash plate position feedback. As a command input interface the control utilizes a SAE J1939 CAN message protocol to provide maximum flexibility for integration into various mobile and stationary drive systems. Such systems may include single or multiple pumps while permitting independent pump control via a centralized controller or PLC. Direct operator interface with the CAN Enabled EDC can also be achieved using the Eaton Ultrionics™ single or dual axis joysticks as well as other commercially available joysticks that integrate a CAN J1939 interface.



Series 2 Variable Displacement Pump
(Shown with proportional control and electronic swash position sensor.)



CAN-Enabled EDC Control Module

Design features and benefits:

- Low control hysteresis (less than 1%) combined with digital displacement command interface for optimal repeatability
- Command resolution down to 0.1% to provide simplified integration with externally controlled closed loop control applications
- Fast dynamic response supported by uniquely designed pump control valves and supporting control algorithms
- Fully encapsulated digital control module with CE marking for EMC and transient protection design for direct connection to vehicle electrical systems
- Easy to integrate pump displacement control via Controller Area Network (SAE J1939 CAN) protocol
- Reliable operation based on field-proven electro-proportional pump displacement control with electronic (non-contacting) swash position feedback sensor
- Dynamic monitoring of pump via GUI
- Advanced control monitoring, diagnostics, and parameter setting possible through a PC-based Graphical User Interface (GUI) software or J1939 messages.

System Interconnect Diagram

The CAN-enabled electronic displacement control (CAN EDC) may be used in conjunction with SAE J1939 CAN capable joysticks or connected to a central vehicle controller through a CAN bus network.



**System Controller or
CAN User Interface Device**

**SAE J1939
CAN Bus**

CAN EDC



**Power
Supply**

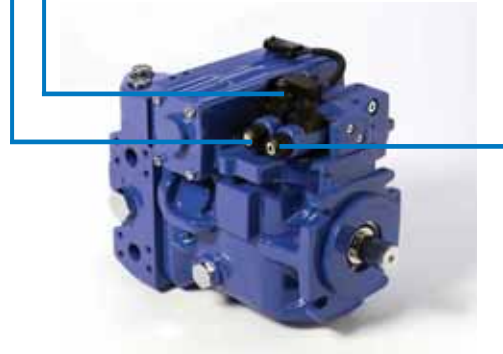

Series 2 Pump

Product Application Guide

Detailed application information may be obtained by requesting Eaton Engineering Guide Document ATS-473. Please contact your Eaton representative to obtain a copy.

CAN EDC and Pump Control Selection

Two control module configurations are available for the CAN EDC (12 volt or 24 volt based on application operating voltage requirements).

EATON PART NUMBER	OPERATING VOLTAGE
801-0014-001	9 – 16 VDC
800-0017-001	17 –32 VDC

Pump Control Selection:

Compatible Series 2 Control Options

This control is compatible with Series 2 pumps containing the proportional control with electronic swash position feedback sensor. Note: The voltage rating of the pump control coils must match the CAN EDC operating voltage rating 12 or 24 volt.

PUMP CONTROL MODEL CODE POSITION 18, 19	CONTROL DESCRIPTION
SE	Solenoid control 12 volt with non-contact feedback sensor with electrical connectors per DIN 43650
SG	Solenoid control 24 volt with non-contact feedback sensor with electrical connectors per DIN 43650

Pump Control Orifice Selection Positions 20, 21, 22

Position 20 Control orifice supply P (Affects on-stroke time)

Code "0" Recommended as ramp rate may be adjusted with command device

Position 21, 22 Control orifice S1 & S2 (Affects on and off-stroke times)

Code "M" .102" [2.59] Recommended as maximum size available to ensure for proper pressure override (POR) function

Pump Displacement Command Structure

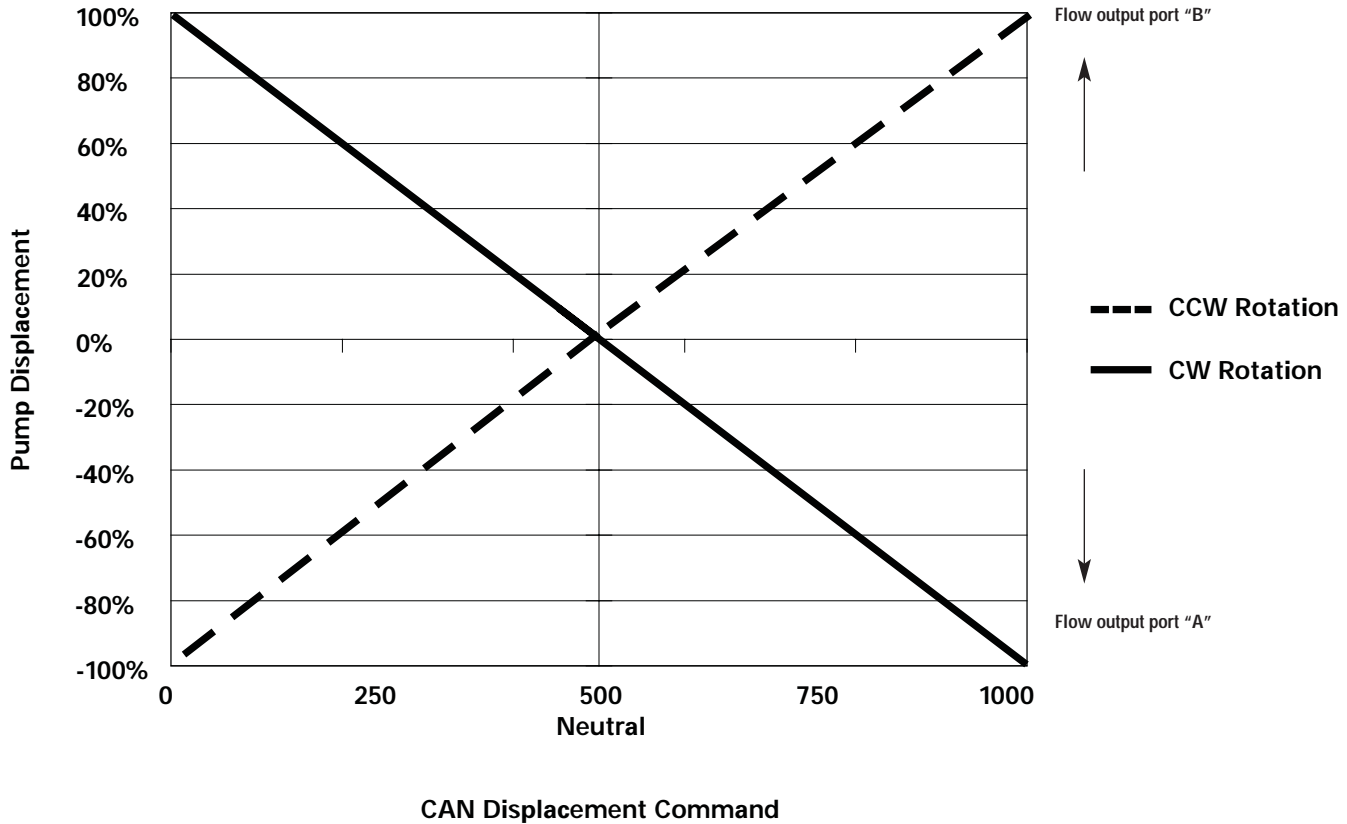

Pump Displacement Command Structure

- Displace command range 0 to 1000 (0.1% Resolution)
- Pump Neutral defined as 500
- Pump swash position command message is expected a minimum of every 100 msec or control shutdown will occur

PUMP ROTATION	DISPLACEMENT COMMAND	PORT FLOW OUT
Clockwise (CW) Right-hand rotation	500 or no command 500.5 – 1000 0 – 499.5	Neutral Port A Port B
Counterclockwise (CCW) Left-hand rotation	500 or no command 500.5 – 1000 0 – 499.5	Neutral Port B Port A

Installation Requirements

- Appropriate wiring practices should be used for installation
- Recommend use of 18 AWG wire per SAE J1128
- The system integrator (manufacturer of the final product) must follow appropriate engineering practices and review all aspects of the application and all of the components used to assure proper operation and reliability.
- Installation of an emergency switch in power supply line is required for shutdown
- Observation of appropriate practices as it relates to EMC, wiring routing, etc.
- Control should be installed in an environmentally-protected enclosure

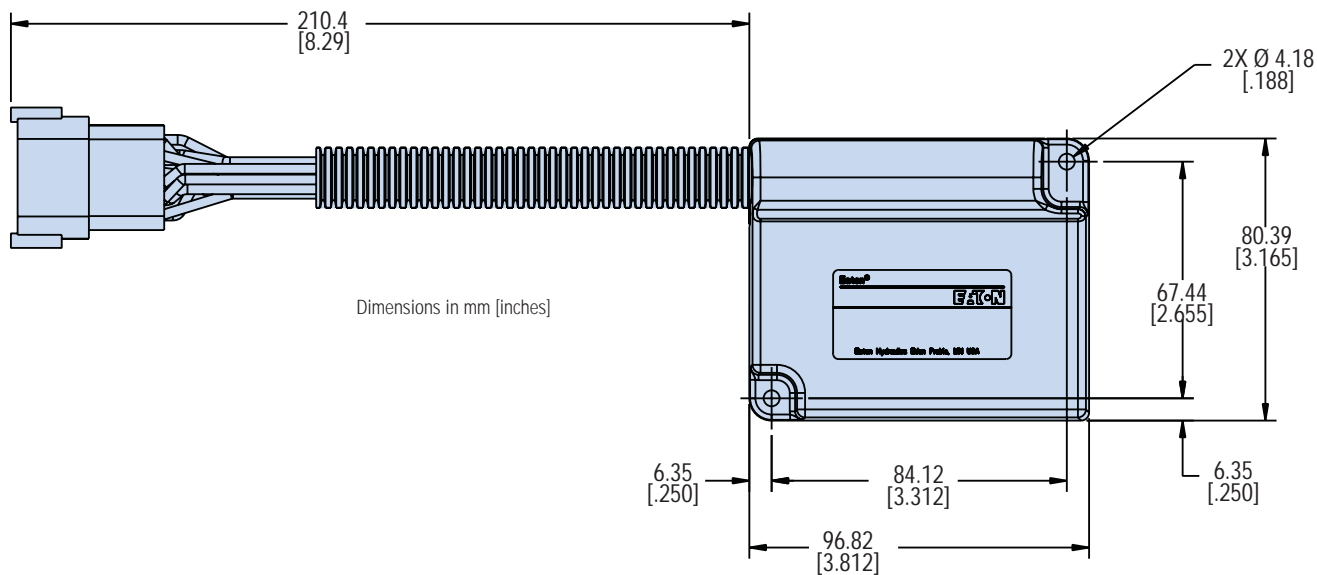

Mount the CAN EDC using two grade 2, #8 screws, tighten to $1.6 \pm .2$ Nm [14.0 ± 1.4 lbf + in]. use washer with a nominal O.D. of 11.05 [.435].

Customer may use alternate bolting option if thread locking is employed. The vehicle mounting surface(s) shall create a flat plane under the CAN EDC mounting features. The mounting surface of the CAN EDC mounting assembly (or potting side) shall mate to the mounting surface of the vehicle.

Connector

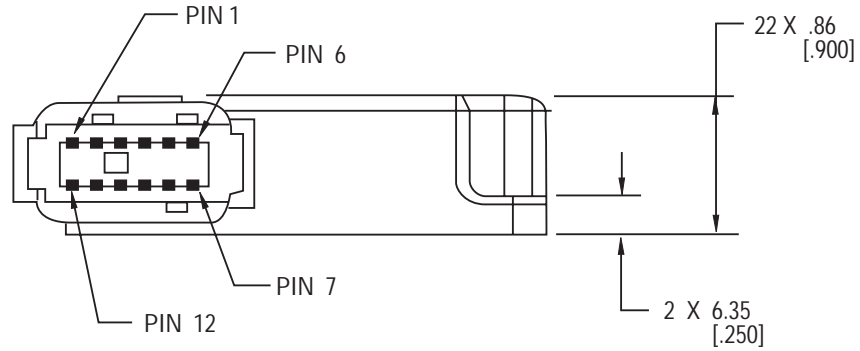

Connector Pin Detail

1 Analog input for swash position sensor	5 PWM Output PWM 1	10 Sensor Supply Return
2 Communication CANbus High	6 PWM Output PWM 2	11 J1939 CANbus Shield (optional)
3 Sensor Supply Sensor	7 PWM Return	12 Communication CANbus Low
4 Battery + Supply (+12VDC)	8 PWM Return	
	9 Battery Gnd Supply (Ground)	

Mating Connector

Connector: Deutsch P/N DTM06-12SA, Qty 1
 Terminal: Deutsch P/N 1062-20-0122, Qty. A/R
 Wedge Lock: Deutsch P/N WM-12S. Qty 1

Graphical User Interface

The Eaton CAN EDC offers the ability to interface with the control for advanced diagnostics and/or set-up of basic parameter settings. The GUI software P/N 5992216-001 is available via download for installation on a PC and must be used in conjunction with a ValueCAN interface device via USB port connection with PC for control communications.

GUI Adjustable Parameters:

- EDC Module address
- Command source address
- Neutral start enable/disable

GUI User's Guide

A detailed GUI User's Guide may be obtained by requesting Eaton document ATS-483.

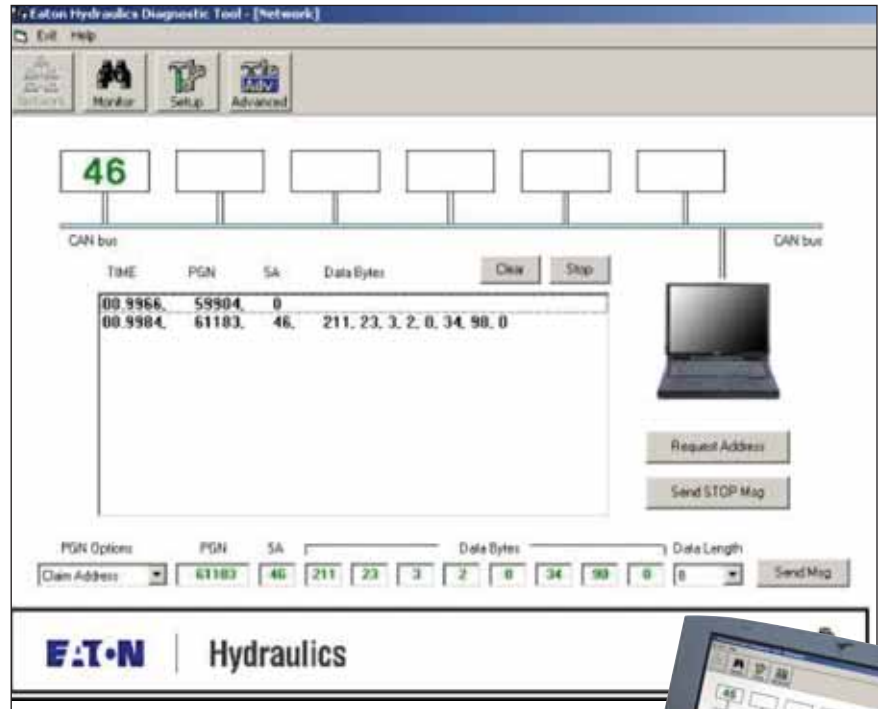

ValueCAN Interface



Graphical User Interface Interconnect Diagram

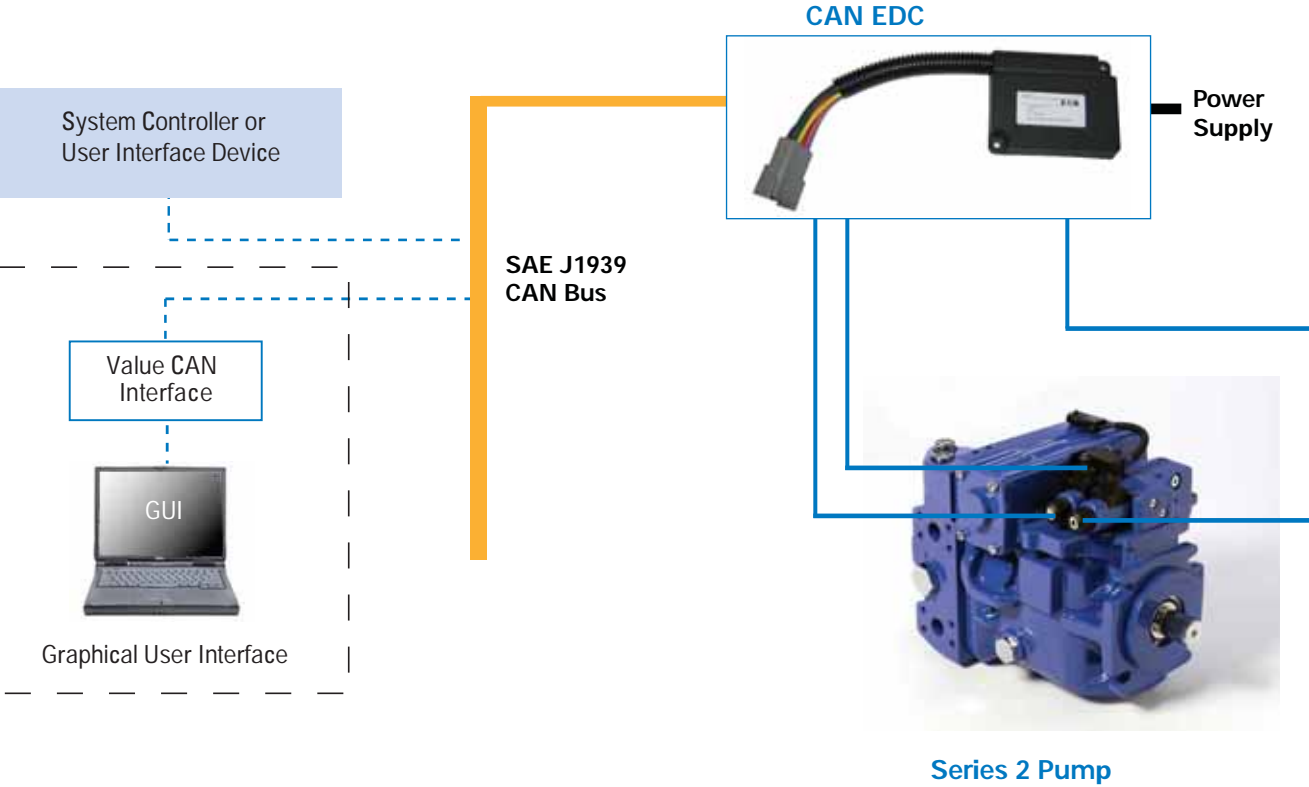

CAN EDC Specifications



CAN-Enabled EDC Control Module

Vehicle Battery

- 12 VDC (9 – 16 Vdc)
(P/N 801-0014-001)
- 24 VDC (17 - 32 Vdc)
(P/N 801-0017-001)

Communication Protocols

- SAE J1939 CAN-bus
vehicle network
- SAE J1939
communication with GUI

Mechanical

- Polymer enclosure
- Encapsulated electronics
- Metri-pak connector
- (2) Mounting flanges:
#8 fasteners

Inputs

- 0-5 Vdc for ESP swash
plate feedback sensor
- SAE J1939 CAN
communications

Environmental

- Operating Temperature: -
40°C to +85°C
- Meets EMC standards
EN 13309-2000
(Construction machinery)
ISO 13766-1999
(Earth moving machinery)
- CE marked for EMC
- Reverse battery and load
dump protection
- Input/output short circuit
protection
- UV resistant
- Random vibration
5.8 Grms
- Shock: 50 G

Outputs

- (2) PWM with current
control
2.5 A max. output each
3.5 A max. module output
- (1) Sensor power supply
Regulated 5.6 VDC

Eaton
14615 Lone Oak Road
Eden Prairie, MN 55344
USA
Tel: 952 937-9800
Fax: 952 974-7722
www.hydraulics.eaton.com

Eaton
20 Rosamond Road
Footscray
Victoria 3011
Australia
Tel: (61) 3 9319 8222
Fax: (61) 3 9318 5714

Eaton
Dr.-Reckeweg-Str. 1
D-76532 Baden-Baden
Germany
Tel: (49) 7221 682-0
Fax: (49) 7221 682-788

