

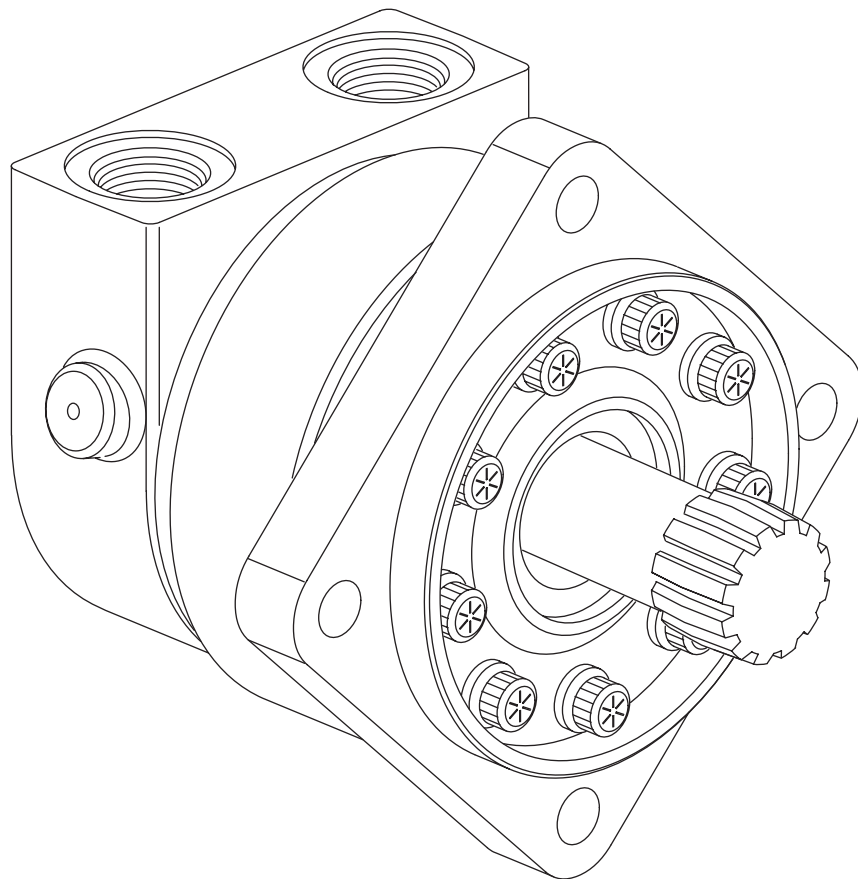

Repair Information



30 Series
VIS Bearingless Motor

002

30 Series Geroler[®] Motors

30 Series Geroler Motors

Disassembly

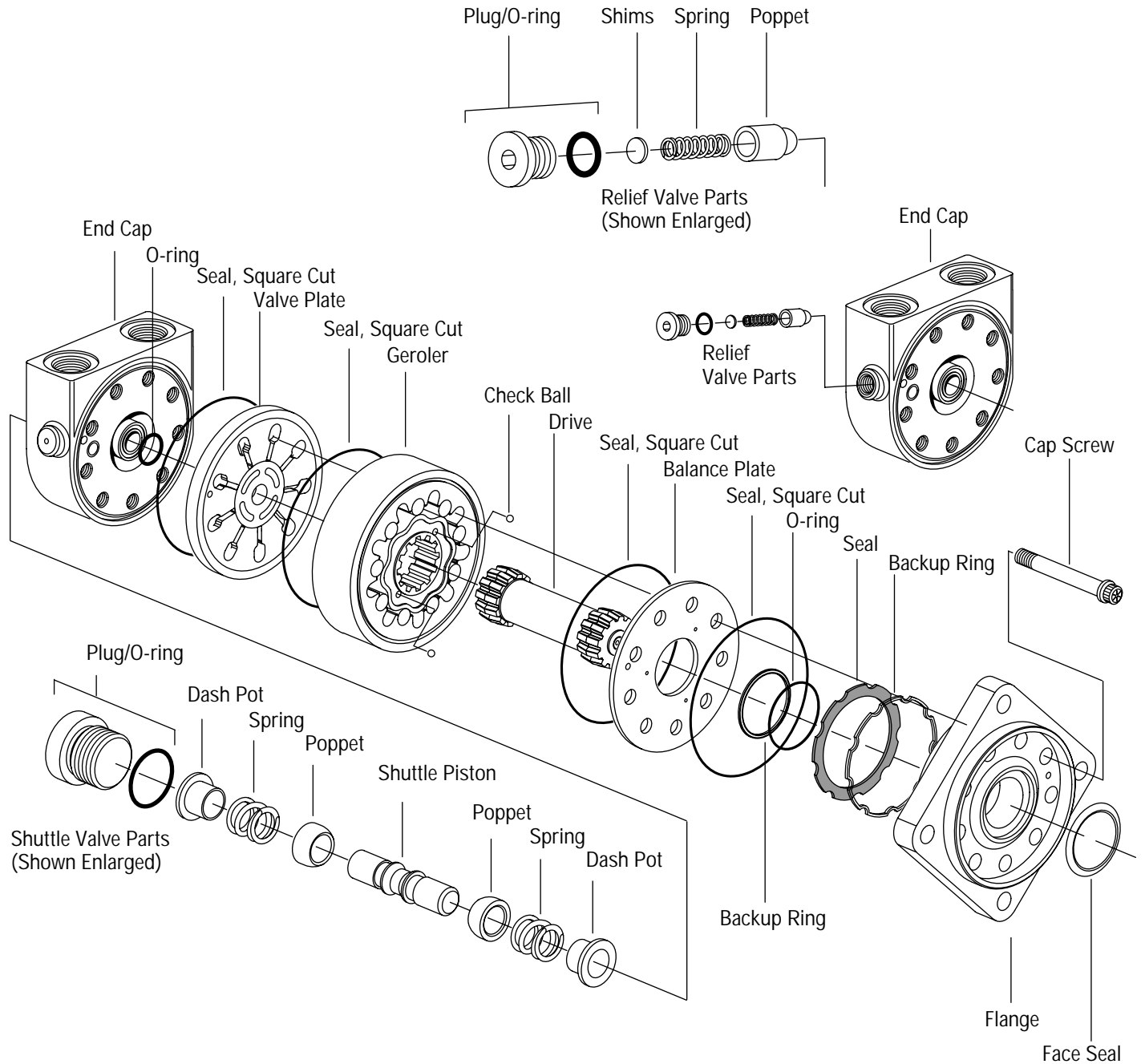

30 Series Geroler Motors

Tools Required

- 1/4 inch Hex Key (Relief Valve Plug)
- 3/16 inch Hex Key (Shuttle Valve Plug)
- 7/16 Socket (12 Point Drive)
- Torque wrench - 45 Nm [400 lb-in] capacity

Disassembly

1 Cleanliness is extremely important when repairing hydraulic motors. Work in a clean area. Before disconnecting the hydraulic motor thoroughly clean the exterior. Remove motor from application and drain the oil from the motor before disassembly.

2 Remove the 9 cap screws and disassemble the motor in the vertical position as shown in Figures 1 and 2. Note placement of small ball checks in Geroler.

3 Remove shuttle valve (and relief valve if applicable) from end cap.

4 Check all mating surfaces. To reduce the chance of leakage, replace any parts that have scratches or burrs. Wash all metal parts in clean solvent. Blow them dry with pressurized air. Do not wipe parts dry with paper towels or cloth as lint in a hydraulic system will cause damage.

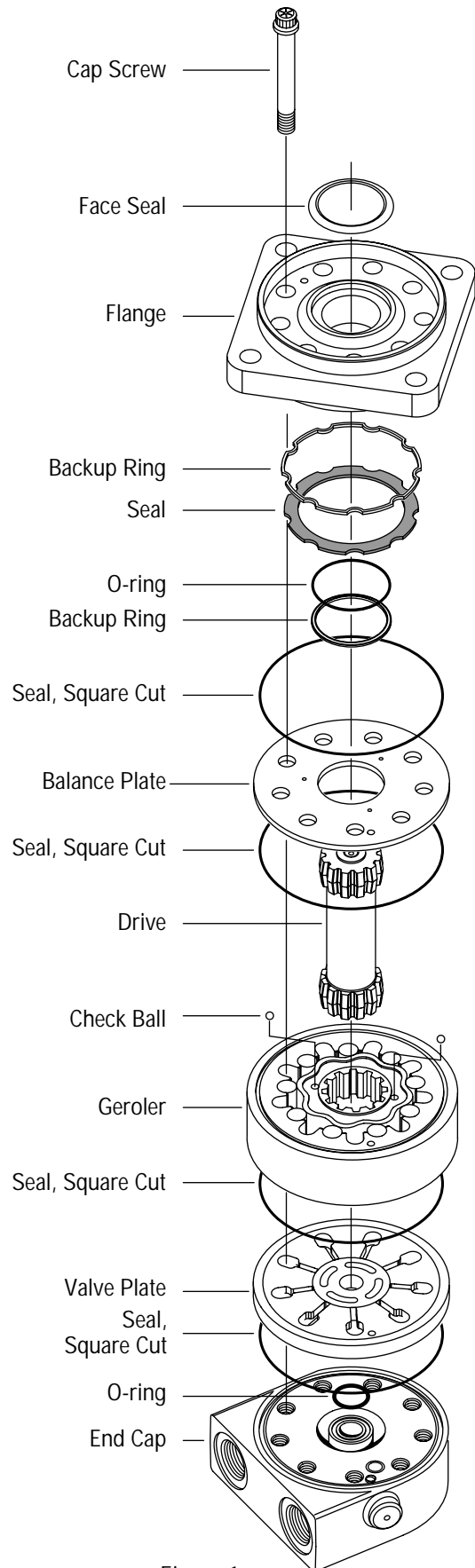

Figure 1

30 Series Geroler Motors

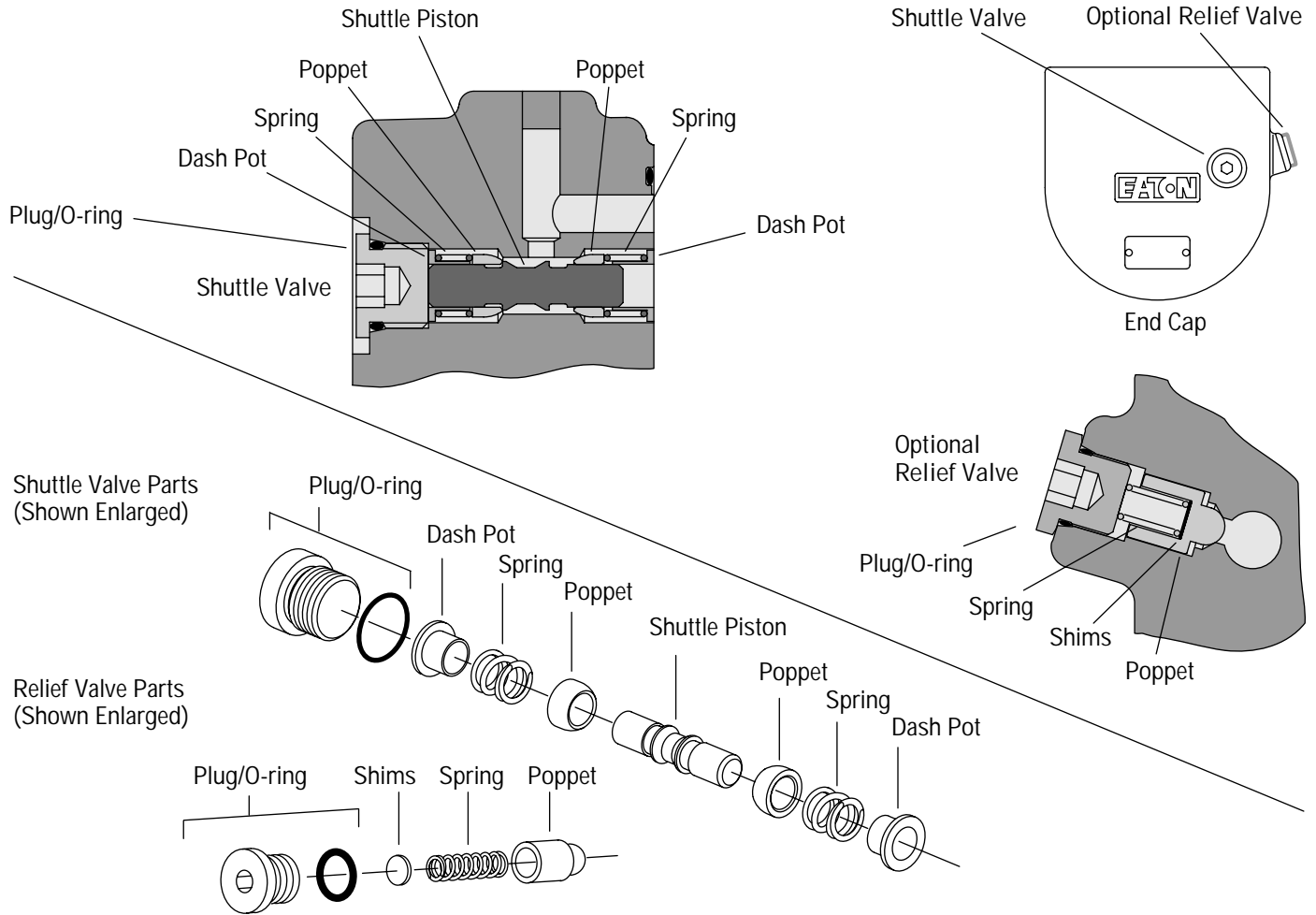

Figure 2

Reassembly

Note: Always use new seals when reassembling hydraulic motors. Refer to parts list 6-152 for seal kit number, replacement parts, and ordering information.

Important: During reassembly, lubricate the new seals with a petroleum jelly such as Vaseline®. Also lubricate machined surfaces with clean hydraulic fluid.

5 Install one poppet, spring and dash pot into shuttle valve bore from valve plate side of end cap.

6 Install shuttle piston from opposite end of shuttle valve cavity.

7 Install one shuttle valve poppet, spring and dash pot onto piston.

8 Install one shuttle valve threaded internal hex plug with o-ring. Shuttle plug threads may have light coat of oil or preservative. Torque plug to 37-45 Nm [324-396 lb-in].

9 For a motor with low pressure relief valve, install poppet, shims, spring and plug. Plug threads may have light coat of oil or preservative. Torque plug to 23-29 Nm [207-253 lb-in].

30 Series Geroler Motors

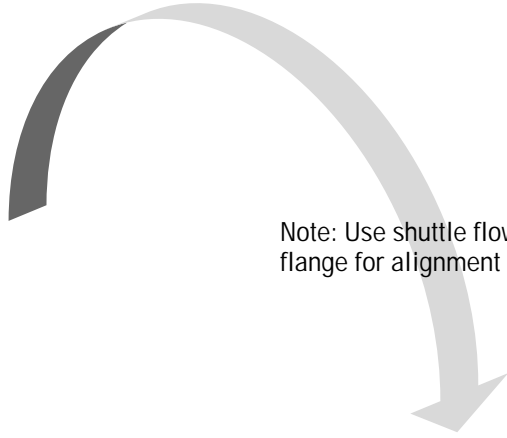

Note: Use shuttle flow hole on back side of flange for alignment — Not this passage.

Note: Assemble these parts as shown below (left).

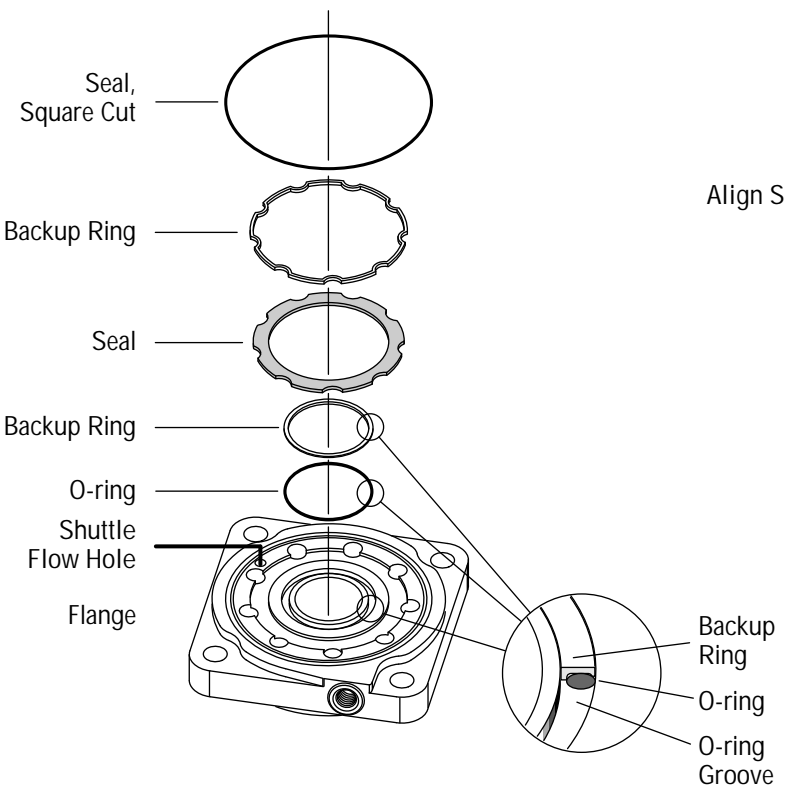

Figure 3

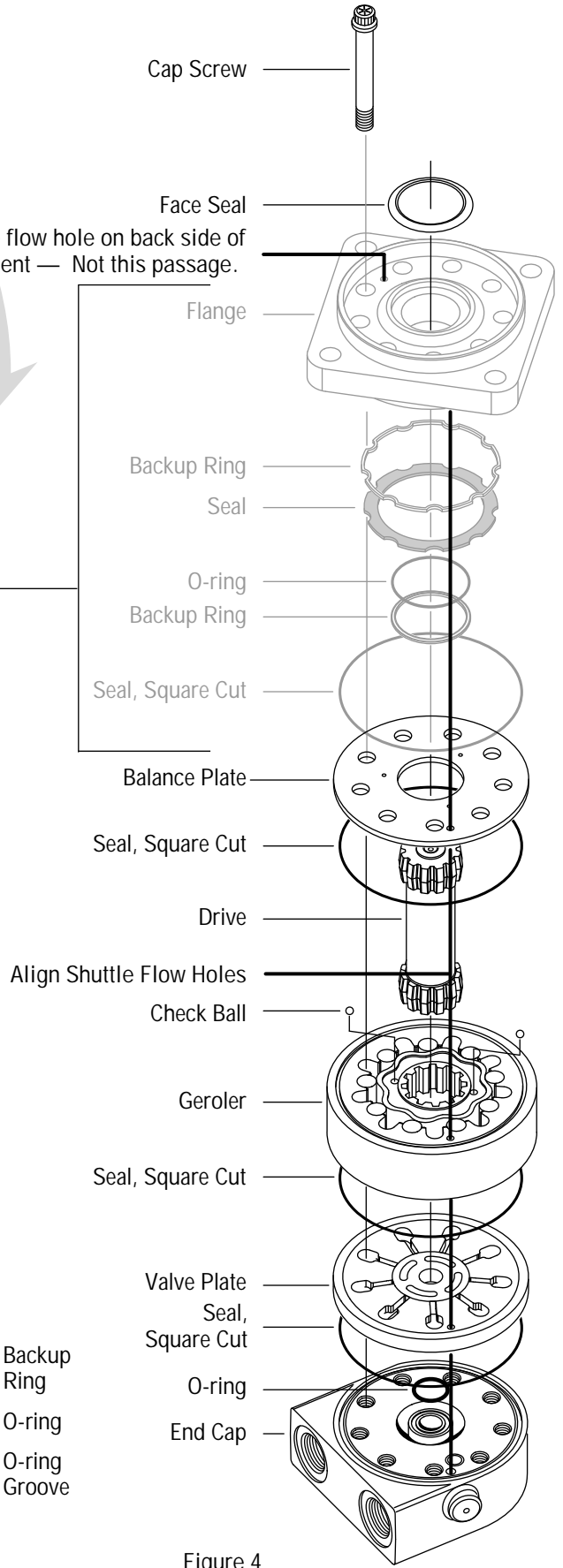

Figure 4

30 Series Geroler Motors

Flange Assembly

Note: Backup rings and seals must have a coating of petroleum jelly to assist in retaining these parts in an inverted position later on in final assembly.

10 Position flange on work bench. With seal grooves up (see Figure 3), install square cut seal (106,0 [4.17] ID), backup ring (94,1 [3.71] OD), seal (77,0 [3.03] ID), o-ring (47,3 [1.86] ID), and backup ring (52,8 [2.08] OD) in flange. Set flange assembly aside, seal side up.

Final Assembly

11 Place end cap on work bench name tag side down, seal grooves up (see Figure 4). Install o-ring (47,3 [1.86] ID), and square cut seal (21,0 [.83] ID) in appropriate grooves.

12 Place valve plate onto end cap. Align bolt holes and shuttle flow hole on valve plate with mating holes on end cap.

13 Install two square cut seals (106,0 [4.17] ID), one on each side of the Geroler. Seal on valve side of Geroler must have a sufficient coating of petroleum jelly to assist in retaining seal in groove.

14 Place Geroler over valve plate. Align bolt holes and shuttle flow hole on Geroler with mating holes on valve plate. Position valve side of star down and spline side up.

15 Place drive into spline of Geroler star.

16 Place two steel balls into seats of Geroler star (one per seat).

17 Place balance plate on Geroler. Align bolt holes and shuttle flow hole on balance plate with mating holes on Geroler.

Note: Before placing flange assembly from step 10, please note location of shuttle flow hole. This will expedite the move from the work bench over onto the balance plate.

18 Carefully invert flange assembly and place onto balance plate with bolt holes and shuttle flow holes in line. Do Not displace seals and backup rings.

19 Install nine cap screws lubricated with DTE-26. Pre-torque each in a crisscross pattern to 61-75 Nm [45-55 lb-ft]. Finally in a crisscross pattern, tighten screws to 75-88 Nm [55-65 lb-ft].

Note: All bearingless motors must be handled with the drive end up. Damage to the balance plate will occur if these bearingless motors are lifted by the drive.

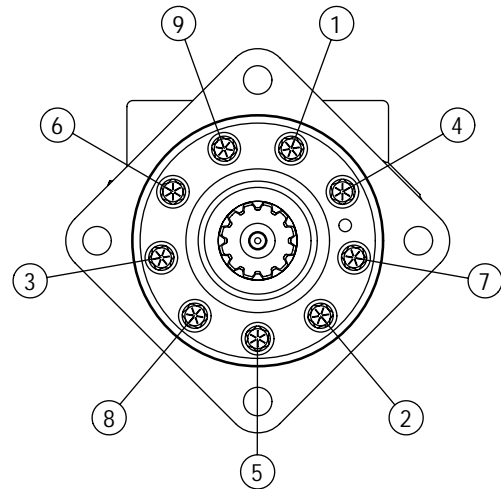

Figure 5

30 Series Geroler Motors

How to Order Replacement Parts

Each Order Must Include the Following:

1. Product Number
2. Date Code
3. Part Name
4. Part Number
5. Quantity of Parts

For More Detailed Information Contact Eaton Corp. Hydraulics Division 15151 Highway 5 Eden Prairie, MN 55344.

- Specifications and Performance Data, Catalog No. 11-112.
- Replacement part numbers and kit information — Parts Information No. 6-152

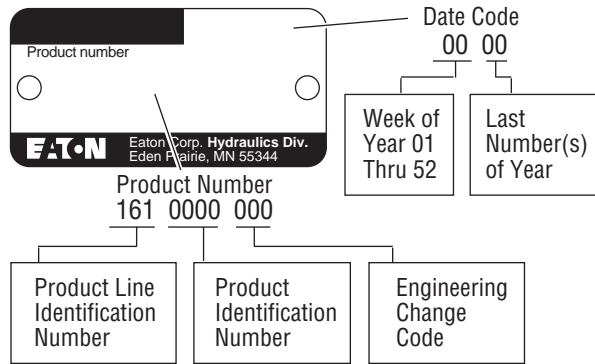

Eaton
Fluid Power Group
Hydraulics Business USA
14615 Lone Oak Road
Eden Prairie, MN 55344
USA
Tel: 952-937-9800
Fax: 952-294-7722
www.eaton.com/hydraulics

Eaton
Fluid Power Group
Hydraulics Business Europe
Route de la Longeraie 7
1110 Morges
Switzerland
Tel: +41 (0) 21 811 4600
Fax: +41 (0) 21 811 4601

Eaton
Fluid Power Group
Hydraulics Business Asia Pacific
11th Floor Hong Kong New World Tower
300 Huaihai Zhong Road
Shanghai 200021
China
Tel: 86-21-6387-9988
Fax: 86-21-6335-3912