



Hydraulics

**Electronic Proportional (EP) Control for
Heavy Duty Series 2 Piston Pumps**

Model 33

Model 39

Model 46

Model 54

Model 64



EP Control for Heavy Duty Series 2 Piston Pumps

Table of Contents

Introduction	3
Parts and Kits	4
Tools Required	5
Disassembly	6
Reassembly	9
Neutral Adjustment	11
Interconnect Schematic	14
Troubleshooting	15
Troubleshooting Reference Settings	18

The purpose of this manual is to provide the necessary information to troubleshoot and repair the EP Control for Eaton® Heavy Duty Series 2 piston pumps.

The EP Control consists of two main parts, the valve assembly and the electronic module.

Note: Many EP Control components are not repairable, i.e., the EP Control electronic module has internal circuitry that is environmentally encapsulated into its housing. Replacing the electronic module with a new one is necessary if the module

is the source of a fault. Complete kits are listed along with individual components should you choose to replace individual components.

CAUTION

In order to assure the most reliable installation and operation of any electronic control, proper component selection and installation procedures must be followed with respect to interconnection wiring harnesses, input command signal devices, fusing, and input power switching.

Appropriate industry practices must be followed to prevent damage of and shorting of all electrical and electronic components caused by environmental hazards and application specific hazards. Typical hazards that damage the wiring harnesses or other components are abrasion,

moving objects, and heat from the engine or exhaust system. Moisture can damage poorly sealed connectors and/or components, causing short circuits and other problems like corrosion.

A switch must be installed in line with (+ battery) power to the electronic module, so that power may quickly be disconnected in case of emergency (component failure or inadvertent commands). A fuse rated at the maximum module operating current (3 Amp) must be installed in the + battery line to the electronic module.

All the electrical connections to the EP Control electronic module must be disconnected prior to performing any

electrical welding on the vehicle or machine. The electronic module and/or the hydraulic pump are not to be used as a connection point for electrical welding equipment.

During initial start-up and/or checkout of the machine after service, the machine must be placed on jack stands to prevent inadvertent movement.

The reliable operation and suitability of this product is dependent upon how it is applied and the other components used in the system. The system integrator must review all aspects of the application and all of the components used to assure proper operation and reliability.

Information contained in this publication is accurate as of the publication date and is subject to change without notice. Performance values are typical values. Customers are responsible for selecting products for their applications using normal engineering methods.

Parts

Parts List

ITEM	PART NO.	QTY.	DESCRIPTION
1	111520-016	1	Electronic Module - 1-6 V Input - 12/24 V
1	111520-020	1	Electronic Module - \pm 4-20 mA Input - 12/24 V
2	101673-175	3	10-24 Button Head Cap Screw (1/8 hex key) - 1.75"
3	16045-203	3	#10 Lockwasher
4	95912-200	5	5/16"-18 Hex Head Cap Screw - 2.75"
5	111501-000	2	Solenoid Tube Subassembly*
6	114241-012	1	Solenoid Coil Subassembly - 12 V (includes two coils and wiring harness)
6	114241-024	1	Solenoid Coil Subassembly - 24 V (includes two coils and wiring harness)
7	4993054-012	1	Valve Assembly - (includes items 5 & 6 - 12 V Solenoid Coil & Tube Subassemblies)
7	4993054-024	1	Valve Assembly - (includes items 5 & 6 - 24 V Solenoid Coil & Tube Subassemblies)
8	110003-000	1	Control Valve Gasket

*Includes necessary O-Rings.

EP Control Kits

KIT NO.	MODEL CODE REFERENCE	KIT DESCRIPTION	INPUT SIGNAL	VALVE ASSEMBLY	ELECTRONIC MODULE	VOLTAGE
9900040-000	EE	EP Ctrl Kit HD Series 2 33/64: 1-6 V input	1-6 V	4993054-012	111520-016	12/24
9900042-000	EG	EP Ctrl Kit HD Series 2 33/64: \pm 4-20 mA input	\pm 4-20 mA	4993054-012	111520-020	12/24 V
9900043-000	EC	EP Ctrl Kit HD Series 2 33/64: 12 V coils w/o electronics	—	4993054-012	—	12 V
9900044-000	ED	EP Ctrl Kit HD Series 2 33/64: 24 V coils w/o electronics	—	4993054-024	—	24 V
990830-000		EP Ctrl Electronic Module 1-6 V	1-6 V	—	111520-016	—
990832-000		EP Ctrl Electronic Module \pm 4-20 mA	\pm 4-20 mA	—	111520-020	—

Note: All kits using Eaton Electronic Modules use 12 V coils.

EP Control Connector Kits

Electronic Module Mating Connector Kit

KIT NO.	PART (QTY.)	DELPHI PACKARD P/N
990762-000 Command Input Signal	Connector (1)	1211 0293
	Terminal (3)	1204 8074
	Cable Seal (3)	1204 8086
	Cavity Plug (1)	1205 9168
	Secondary Lock (1)	1205 2845
Power Supply	Connector (1)	1205 2641
	Terminal (2)	1204 8074
	Cable Seal (2)	1204 8086
	Secondary Lock (1)	1205 2634

Recommended wire size: 16 - 18 AWG
 Recommended cable diameter: 2.03 - 2.80 mm
 Alternate reference source: Pioneer Standard Electronics 1-800-257-6613
www.pios.com

Solenoid Coil Mating Connector Kit

(not needed when using an Eaton Electronic Module)

KIT NO.	PART (QTY.)	DELPHI PACKARD P/N
9900023-000	Connector (1)	1218 6568
	Terminal (4)	1204 8074
	Cable Seal (4)	1204 8086
	Secondary Lock (1)	1204 7948

Recommended wire size: 16 - 18 AWG
 Recommended cable diameter: 2.03 - 2.80 mm
 Alternate reference source: Pioneer Standard Electronics 1-800-257-6613
www.pios.com

Solenoid Connector Update Kit

KIT NO.	PART (QTY.)	DELPHI PACKARD P/N
9900045-000	Tool (1)	1209 4429
	4-Pin Housing Connector (Female) (1)	1218 6568
	4-Pin Housing Connector (Male) (1)	1218 6271

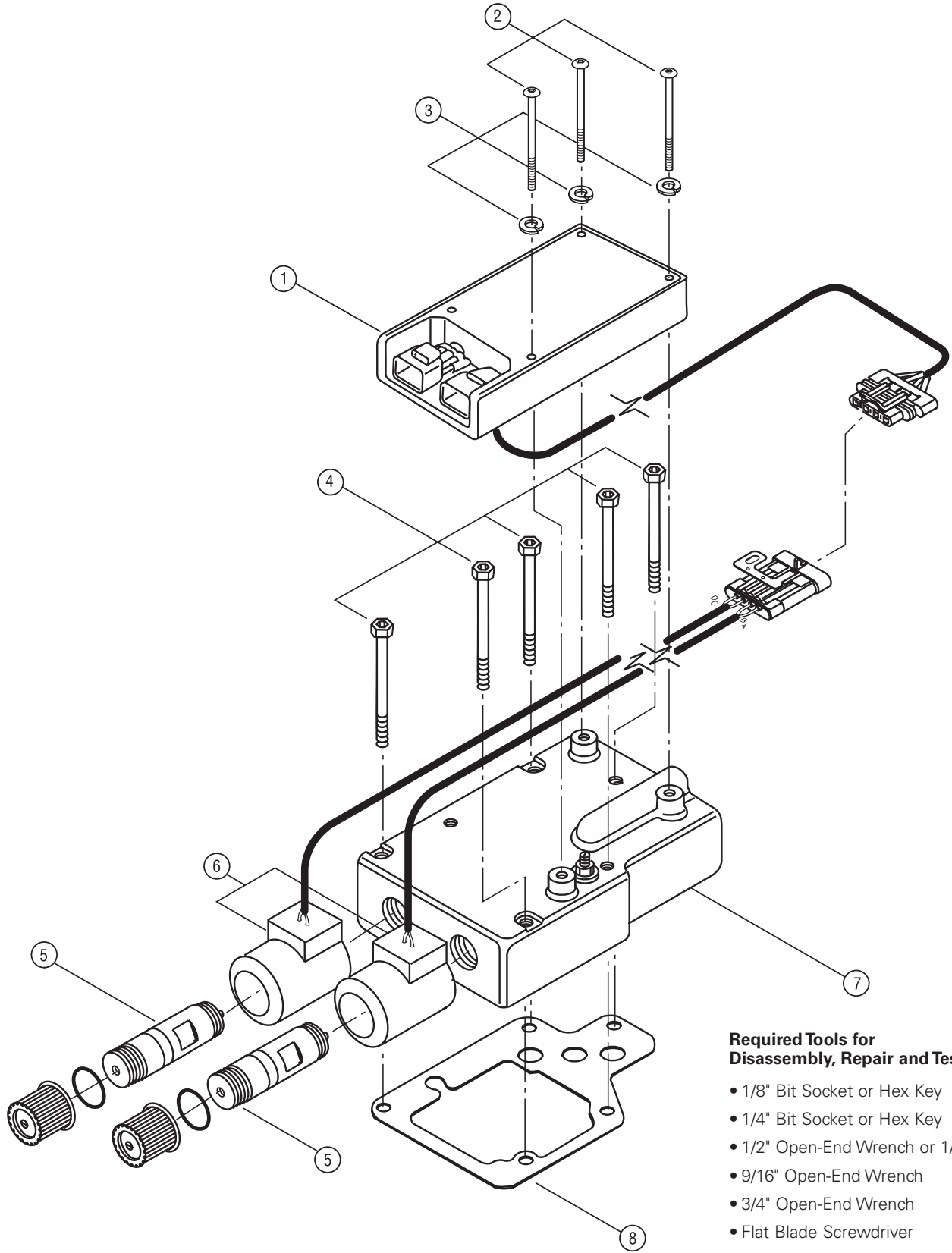

Required Tools for Disassembly, Repair and Test

- 1/8" Bit Socket or Hex Key
- 1/4" Bit Socket or Hex Key
- 1/2" Open-End Wrench or 1/2" Socket
- 9/16" Open-End Wrench
- 3/4" Open-End Wrench
- Flat Blade Screwdriver
- 12 VDC Power Supply or Battery
- Voltage Ohm Meter (VOM)
- Charge Pressure Gauge

Disassembly

Step 1

Disconnect all power to the input device. Carefully disconnect the three-pin connector between the EP Control electronics module and the command input device by releasing the connector latches. Thoroughly clean the outside of the EP Control and surrounding pump surface.



Step 2

Using a 1/8" bit socket or hex key, remove the three 10-24 button head cap screws and lockwashers.



Step 3

Disconnect the four-pin connector between the EP Control electronic module and the solenoid coils. Caution must be used when disconnecting these connectors as they are latched with keepers.



Step 4

Using a Phillips screwdriver, remove the set screw and lockwasher which hold the Metri-Pack® connector to the EP Control valve assembly.

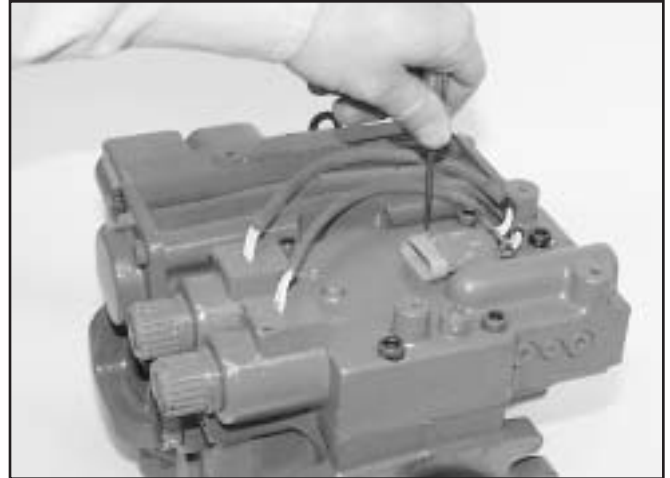

Step 5

The two solenoid coils can be removed by turning each solenoid tube knob counterclockwise. Remove the knob and associated O-ring. Slide the coil off the tube subassembly. Repeat for other coil.

Note: Each coil is stamped with a position number "1" and "2" and the voltage "12V" or "24V". There are also numbers stamped on the valve assembly indicating positions #1 and #2. When reassembling the coils, the numbers stamped on the coil and valve assembly must match. Refer to page 3.



Step 6

Using a 3/4" open-end wrench, remove solenoid tube subassembly by turning counterclockwise. Repeat on the second tube.

If just replacing the coil and tube subassemblies, skip to Reassembly, Step 16.



Step 7

Using a 1/4" hex key (or 1/2" socket/end wrench), remove the five 5/16"-18 hex head cap screws.



Step 8

Carefully lift the valve assembly straight up away from the pump. Take care not to damage the feedback link or swashplate link.



Step 9

Caution must be used so that the swashplate link remains seated on the swashplate pin.



Step 10

Remove and discard the control valve gasket.



Step 11

In most cases it will not be necessary to remove the control orifices that are staked in the pump housing. Only remove if the orifice size needs to be changed. The orifice size is stamped on the flat plate orifices in the pressure, servo-1, and servo-2 ports.



Reassembly

Step 12

Clean the EP Control mounting surface. Install a new control valve gasket by aligning with screw and porting holes.



Step 13

Carefully align the EP Control valve assembly to the pump housing. Align the hole in the EP Control feedback link with the swashplate link.

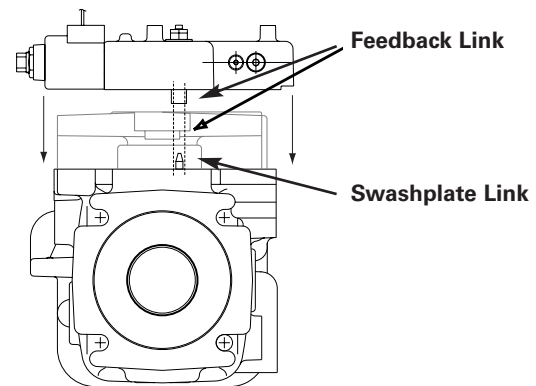

Step 14

Carefully lower the valve assembly straight down onto the pump, guiding the EP Control feedback link onto the swashplate link. The EP Control feedback link must engage the swashplate link.



Step 15

Using a 1/4" hex key (or 1/2" socket/end wrench), tighten the five 5/16"-18 hex head cap screws. Torque to 22 ± 2 lbf-ft.



Step 16

Locate the new solenoid tube subassembly. Each solenoid tube subassembly comes with new O-rings installed on the tubes. The tube subassemblies are interchangeable.

Step 17

Using a 3/4" open-end wrench, replace the tube subassembly by turning clockwise. Torque the solenoid tube to 22 ± 2 lbf-ft. Repeat on other tube subassembly.

Replace the coils. **Note:** The position number stamped on the coil and the valve assembly must match.

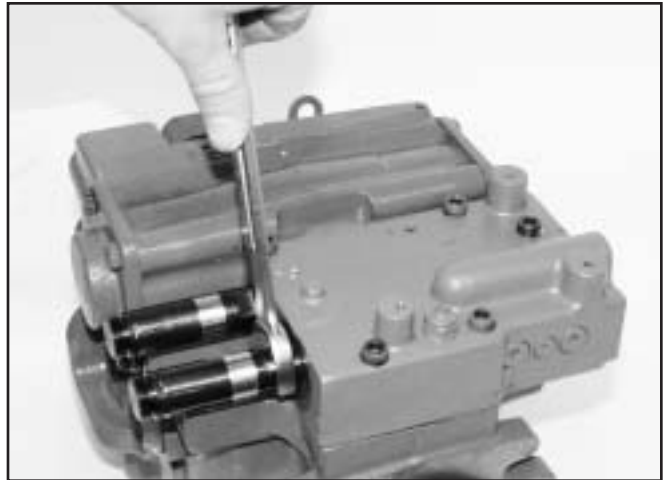

Step 18

Attach the retaining knob, and hand tighten. The knob should be tightened until snug and then another 1/2 turn. If available, the knob should be torqued to 12 ± 1 lbf-ft.



Step 19

Neutral Adjustment

Caution: All hoses and fittings must be connected, and the pump ready for operation before attempting to check neutral adjustment. Electrical wiring harnesses for the solenoid coils and command input should be left disconnected while adjusting neutral.

- A. Disengage the input drive to vehicle or elevate wheels.
- B. Install charge pressure gauge. A 0-1000 psi or 0-1500 psi pressure gauge is recommended.

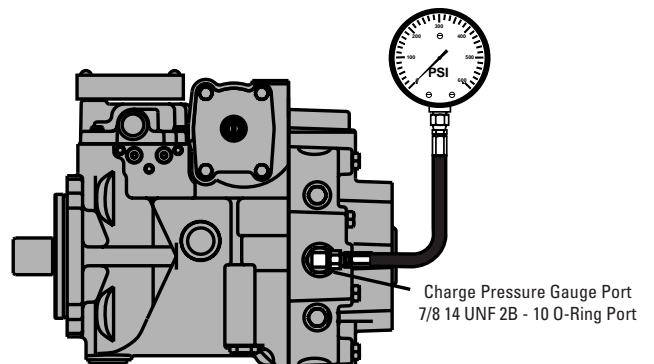

- C. Start the prime mover.
- D. Loosen the locknut holding the neutral adjustment screw until it is just snug enough that the threaded screw can be rotated. Use a 9/16" end wrench to hold the locking nut while rotating the neutral adjustment screw.
- E. Note the number stamped on the cap of the low pressure relief valve. -022 is 220 psig (15 bar), -030 is 305 psig (21 bar), etc. This will be the high setting. Settings can vary from 220 psig (15 bar) to 410 psig (28 bar).
- F. Slowly rotate the neutral adjustment screw clockwise until charge pressure drops to its low setting. Mark the neutral adjustment screw location.

Note: The charge pressure low setting is usually 40-60 psig lower than the high setting.
- G. Rotate the neutral adjustment screw counterclockwise. The charge pressure will rise. Continue turning counterclockwise until the pressure drops again to its low setting. Mark the neutral adjustment screw location.
- H. Rotate the neutral adjustment screw to the position between the two marks.
- I. Carefully hold adjustment screw while torquing locknut. Torque locknut to 10 ± 1 lbf·ft. Neutral adjustment is completed.

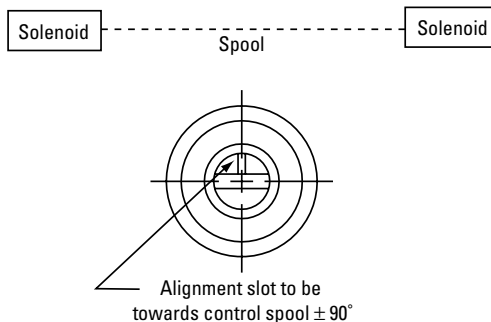
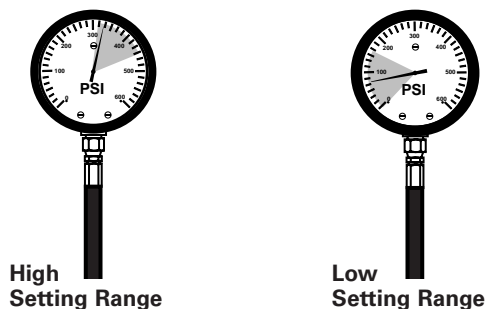
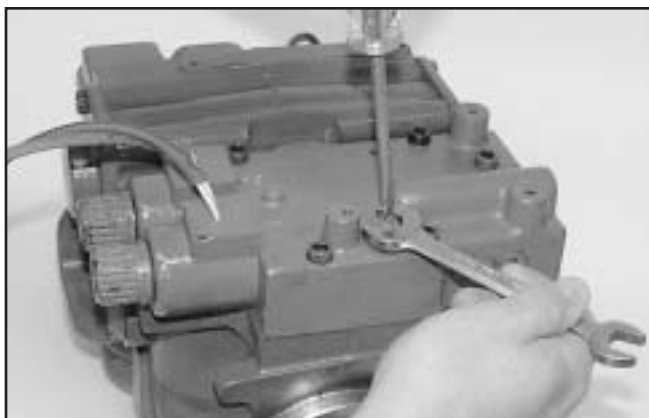

Step 20

Using a Phillips screwdriver, replace the lockwasher and tighten the set screw which hold the Metri-Pack® connector onto the valve assembly.

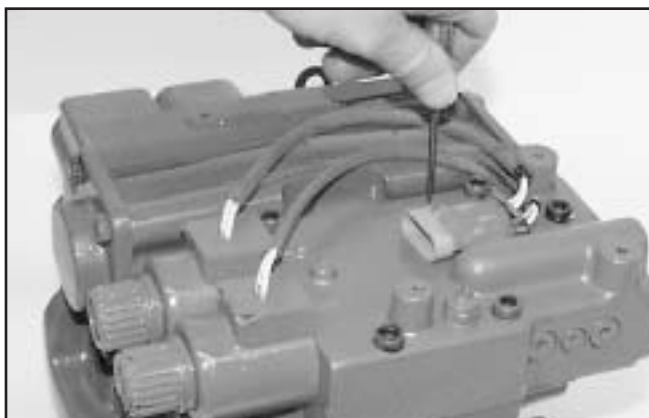

Step 21

Connect the EP Control electronic module and the solenoid coils. The four-pin connectors must be latched securely.



Step 22

Carefully position the electronic module. Tuck all cables under the module. **Caution:** Avoid pinching cables at mounting points.

Install the three lockwashers and three 10-24 button head cap screws. Torque the three screws to 40-48 lbf-in.

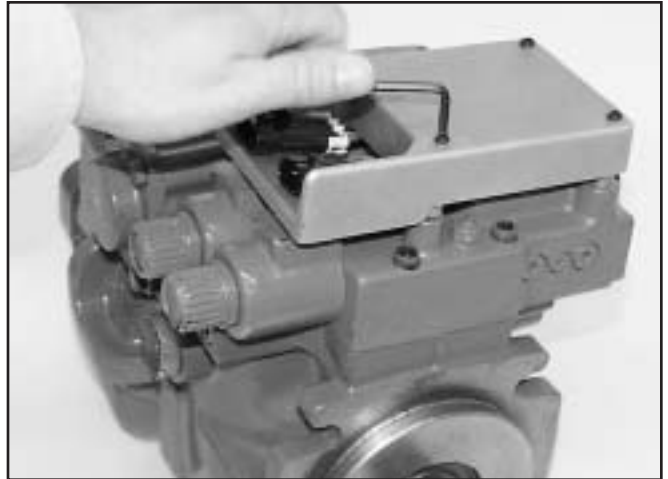

Step 23

Power should still be disconnected to the input device. Connect the command input device to the three-pin connector on the electronic module.

Step 24

Connect the electrical power source to the two-pin connector on the EP Control electronic module. Install a 3 Amp SLO-BLO® fuse. Refer to the Interconnect Schematic on page 13. Recheck your work and then reconnect the power to the vehicle or system.

Step 25

The pump is now ready to return to operation.



Interconnect Schematic

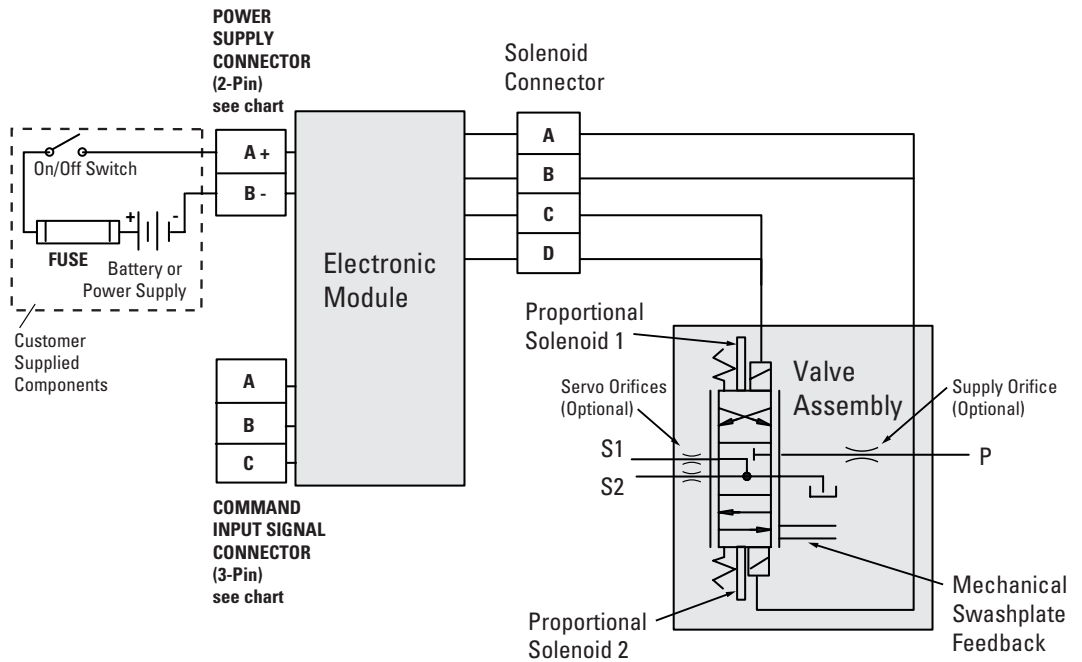

Command Input Signal Connector

COMMAND INPUT SIGNAL	PINS	WIRE COLOR	SIGNAL
1 to 6 Vdc Potentiometric	A	Black	Ref Low - 1 Vdc
	B	Green	Command (wiper)
	C	Red	Ref Hi - 6 Vdc
±4-20 mA Current Loop	A	Orange	Loop Return
	B	White	Loop In
	C	No Connection Required*	

*EP Control Electronic Module Mating Connector Kit 990762-000 contains plug used to seal mating end connector.

Power Supply Connector

PINS	WIRE COLOR	SIGNAL
A	Red	+ Supply Voltage
B	Black	Supply Return

Fuse Rating

3 Amp SLO-BLO® (Time Delay) fuse for 12-24 Vdc system - customer supplied

Pump Displacement vs. Input Signal

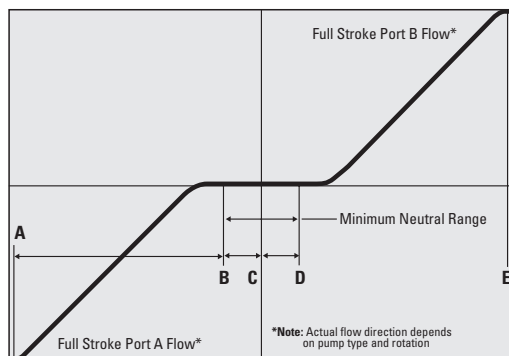

Typical Control Characteristics

	A (MAX)	B (MIN)	C	D (MIN)	E (MAX)
Command Input Signal					
1-6 Vdc	1.5 Vdc	3.3 Vdc	3.5 Vdc	3.7 Vdc	5.5 Vdc
±4-20 mA	-20 mA	-4.5 mA	0 mA	+4.5 mA	+20 mA
Shaft Rotation					
CCW	Solenoid #2		Neither	Solenoid #1	
	Flow OUT port "B"		No flow	Flow OUT port "A"	
CW	Solenoid #2		Neither	Solenoid #1	
	Flow OUT port "A"		No Flow	Flow OUT port "B"	

Note: The +20 mA command input signal configuration operates the pump in one direction. The customer has to change the polarity on the -20 mA signal to operate the pump in the opposite direction.

Troubleshooting

SYMPTOM	CAUSE	ACTION
No Flow in Either Direction	Defective Power Connection, or Loose Wires	<u>Check Power Input.</u> Disconnect the two-pin connector from the power supply to the EP Control electronic module. Inspect the two connectors for corrosion, loose wires or broken wires. Measure the DC voltage across pins "A" and "B" at the connector. The reading should be between 9 to 30 Vdc.
	Command Signal Missing	<u>Check Command Input Signal.</u> Disconnect the three-pin connector from the command input device to the EP Control electronic module. Inspect the two connectors for corrosion, loose contacts, loose wires and broken wires. If 1-6 Vdc joystick or potentiometer is used, measure the DC voltage across pins "A" and "B" at the connector. Move the joystick or potentiometer position. The voltage reading will be approximately 2.5 volts DC at joystick neutral or the half range position of the potentiometer. The DC voltage will be approximately 5 volts at one end of the joystick or potentiometer travel. At the opposite end of travel the DC voltage will be approximately zero. If ± 4 -20 mA current loop input is used, measure the DC voltage across pins "A" and "B" at the connector. The DC voltage reading should be approximately zero at zero input current which occurs at command input neutral. The DC voltage reading should be approximately ± 5 volts for input command currents of ± 20 mA respectively.
	Defective Solenoid Coil	<u>Check Solenoid Coil.</u> Disconnect the two-pin power supply and the three-pin command input device connectors from the EP Control electronic module. Inspect the connectors for corrosion, loose contacts, loose wires and broken wires. Remove the EP Control electronic module. Refer to instructions on page 5. Disconnect the two mating four-pin connectors. Measure the coil resistance across the designated pins at the solenoid four-pin connector. Refer to the Solenoid 4-pin Connector chart on page 18 for typical readings.
	Defective Electronic Module	<u>Check Electronic Module.</u> Disconnect the two-pin power supply and the three-pin command input device connectors from the EP Control electronic module. Inspect the connectors for corrosion, loose contacts, loose wires and broken wires. Remove the EP Control electronic module. Refer to instructions on page 5. Caution: The engine or motor driving the pump should <u>not</u> be running. Connect command input device and power to the module. Measure the current to the coil at the four-pin connector. Activate the input device end to end and at neutral. Monitor the current on one coil, and then on the other. Refer to Command Input Device chart on page 18 for typical readings.
	Manual Override Does Not Function	<u>Check Manual Override.</u> Disconnect two-pin power supply and the three-pin command input device connectors from the EP Control electronic module. Inspect the connectors for corrosion loose contacts, loose wires and broken wires. Remove the valve assembly. Refer to instructions on page 7. Use a small Phillips screwdriver to push on the manual override of the solenoid tube's solenoid tube actuator pin.
Flow Only in One Direction	Command Signal Incorrect	<u>Check Command Input Signal.</u> Disconnect the three-pin command input device connector from the EP Control electronic module. Inspect the two connectors for corrosion, loose contacts, loose wires and broken wires. If 1-6 Vdc joystick or potentiometer is used, measure the DC voltage across pins "A" and "B" at the connector. Move the joystick or potentiometer position. The voltage reading will be approximately 2.5 volts DC at joystick neutral or the half range position of the potentiometer. The DC voltage will be approximately 5 volts at one end of the joystick or potentiometer travel. At the opposite end of travel the DC voltage will be approximately zero. If ± 4 -20 mA current loop input is used, measure the DC voltage across pins "A" and "B" at the connector. The DC voltage reading should be approximately zero at zero input current which occurs at command input neutral. The DC voltage reading should be approximately ± 5 volts for input command currents of ± 20 mA respectively.

Troubleshooting

SYMPTOM:	CAUSE:	ACTION:
Flow Only in One Direction (con't)	Defective Solenoid Coil	<u>Check Solenoid Coil.</u> Disconnect the two-pin power supply and the three-pin command input device connectors from the EP Control electronic module. Inspect the connectors for corrosion, loose contacts, loose wires and broken wires. Remove the EP Control electronic module. Refer to instructions on page 5. Disconnect the two mating four-pin connectors. Measure the coil resistance across the designated pins at the solenoid four-pin connector. Refer to the Solenoid 4-pin Connector chart on page 18 for typical readings.
	Defective Solenoid Tube Subassembly	<u>Check Solenoid Tube Subassembly.</u> Disconnect the two-pin power supply and the three-pin command input device connectors from the EP Control electronic module. Inspect the connectors for corrosion, loose contacts, loose wires and broken wires. Remove the two solenoid tube subassemblies. Visually inspect the actuator pin in the tube subassembly. The pin should be free to move.
	Defective Electronic Module	<u>Check Electronic Module.</u> Disconnect the two-pin power supply and the three-pin command input device connectors from the EP Control electronic module. Inspect the connectors for corrosion, loose contacts, loose wires and broken wires. Remove the EP Control electronic module. Refer to instructions on page 5. Caution: The engine or motor driving the pump should <u>not</u> be running. Connect command input device and power supply to the electronic module. Measure the current to the coil at the four-pin connector. Activate the input device end to end and at neutral. Monitor the current on one coil, and then on the other. Refer to Command Device Input Chart on page 18 for typical readings.
Flow in Neutral	Command Signal Incorrect	<u>Check Command Input Signal.</u> Disconnect the three-pin command input device connector from the EP Control electronic module. Inspect the two connectors for corrosion, loose contacts, loose wires and broken wires. If 1-6 Vdc joystick or potentiometer is used, measure the DC voltage across pins "A" and "B" at the connector. Move the joystick or potentiometer position. The voltage reading will be approximately 2.5 volts DC at joystick neutral or the half range position of the potentiometer. The DC voltage will be approximately 5 volts at one end of the joystick or potentiometer travel. At the opposite end of travel the DC voltage will be approximately zero. If ± 4 -20 mA current loop input is used, measure the DC voltage across pins "A" and "B" at the connector. The DC voltage reading should be approximately zero at zero input current which occurs at command input neutral. The DC voltage reading should be approximately ± 5 volts for input command currents of ± 20 mA respectively.
	Neutral Out of Adjustment	<u>Check Neutral Adjustment.</u> Disconnect the two-pin power supply and the three-pin command input device connectors from the EP Control electronic module. Inspect the connectors for corrosion, loose contacts, loose wires and broken wires. Remove the EP Control electronic module. Refer to instructions on page 5. Disconnect the two four-pin solenoid connectors. Follow instructions for setting neutral on page 11 Step 19.
Flow Limited, Cannot Achieve Full Pump Stroke	Command Signal Incorrect	<u>Check Command Input Signal.</u> Disconnect the three-pin command input device connector from the EP Control electronic module. Inspect the two connectors for corrosion, loose contacts, loose wires and broken wires. If 1-6 Vdc joystick or potentiometer is used, measure the DC voltage across pins "A" and "B" at the connector. Move the joystick or potentiometer position. The voltage reading will be approximately 2.5 volts DC at joystick neutral or the half range position of the potentiometer. The DC voltage will be approximately 5 volts at one end of the joystick or potentiometer travel. At the opposite end of travel the DC voltage will be approximately zero. If ± 4 -20 mA current loop input is used, measure the DC voltage across pins "A" and "B" at the connector. The DC voltage reading should be approximately zero at zero input current which occurs at command input neutral. The DC voltage reading should be approximately ± 5 volts for input command currents of ± 20 mA respectively.

Troubleshooting

SYMPTOM:	CAUSE:	ACTION:
Flow Limited, Cannot Achieve Full Pump Stroke (con't)	Defective Electronic Module	<u>Check Electronic Module.</u> Disconnect the two-pin power supply and the three-pin command input device connectors from the EP Control electronic module. Inspect the connectors for corrosion, loose contacts, loose wires and broken wires. Remove the EP Control electronic module. Refer to instructions on page 5. Caution: The engine or motor driving the pump should <u>not</u> be running. Connect command input device and power supply to the electronic module. Measure the current to the coil at the four-pin connector. Activate the input device end to end and at neutral. Monitor the current on one coil, and then on the other. Refer to Command Input Device chart on page 18 for typical readings.
	Manual Override Does Not Function	<u>Check Manual Override.</u> Disconnect the two-pin power supply and the three-pin command input device connectors from the EP Control electronic module. Inspect the connectors for corrosion loose contacts, loose wires and broken wires. Remove the valve assembly. Refer to instructions on page 7. Use a small Phillips screwdriver to push on the manual override of the solenoid tube's actuator pin should move the spool.
Does Not Return to Neutral	Command Signal Incorrect	<u>Check Command Input Signal.</u> Disconnect the three-pin command input device connector from the EP Control electronic module. Inspect the two connectors for corrosion, loose contacts, loose wires and broken wires. If 1-6 Vdc joystick or potentiometer is used, measure the DC voltage across pins "A" and "B" at the connector. Move the joystick or potentiometer position. The voltage reading will be approximately 2.5 volts DC at joystick neutral or the half range position of the potentiometer. The DC voltage will be approximately 5 volts at one end of the joystick or potentiometer travel. At the opposite end of travel the DC voltage will be approximately zero. If ± 4 -20 mA current loop input is used, measure the DC voltage across pins "A" and "B" at the connector. The DC voltage reading should be approximately zero at zero input current which occurs at command input neutral. The DC voltage reading should be approximately ± 5 volts for input command currents of ± 20 mA respectively.
	Neutral Out of Adjustment	<u>Check Neutral Adjustment.</u> Disconnect the two-pin power supply and the three-pin connectors from the EP Control electronic module. Inspect the connectors for corrosion, loose contacts, loose wires and broken wires. Remove the EP Control electronic module. Refer to instructions on page 5. Disconnect the two solenoid four-pin connectors. Follow instructions for setting neutral on page 11 Step 19.

Troubleshooting Reference Settings

Solenoid 4-Pin Connector

PINS	SOLENOID	12 VOLT COIL	24 VOLT COIL
A & B	Coil 1	5 ohms	21 ohms
C & D	Coil 2	5 ohms	21 ohms

Note: Only 12 volt coils are used with EP Control electronics module

Joystick Position

DC VOLTAGE MEASURED ACROSS DESIGNATED PINS AT THE CUSTOMER THREE-PIN CONNECTOR	
	A to B
Full-Forward	5 Vdc
Neutral	2.5 Vdc
Full-Reverse	0 Vdc

Command Input Device – 12/24 Volt Systems (5 Ω coils)

	CURRENT TO COIL 1 PINS A & B YELLOW & WHITE WIRES	CURRENT TO COIL 2 PINS C & D ORANGE & BLACK WIRES
Max command in one direction	Minimum 1.5 A Maximum 2.0 A	0 A 0 A
Neutral	0 A	0 A
Max command in the same direction	0 A 0 A	Minimum 1.5 A Maximum 2.0 A

Eaton
14615 Lone Oak Road
Eden Prairie, MN 55344
Telephone: 952 937-9800
Fax: 952 974-7130
www.hydraulics.eaton.com

Eaton
20 Rosamond Road
Footscray
Victory 3011
Australia
Tele: (61) 3 9319 8222
Fax: (61) 3 9318 5714

Eaton
46 New Lane, Havant
Hampshire PO9 2NB
England
Tele: (44) 23 92 486 451
Fax: (44) 23 92 487 110

EAT•N

Hydraulics

© 2002 Eaton Corporation
All Rights Reserved
Printed in USA
Document No. E-PUPI-TS001
Supersedes 08-10-0002 EN-0901
September 2002