

L=4 x STROKE

L=1/2 STROKE

**EAT•N**

**Vickers**

## Industrial Welded Cylinders

Technical Manual

Series WH

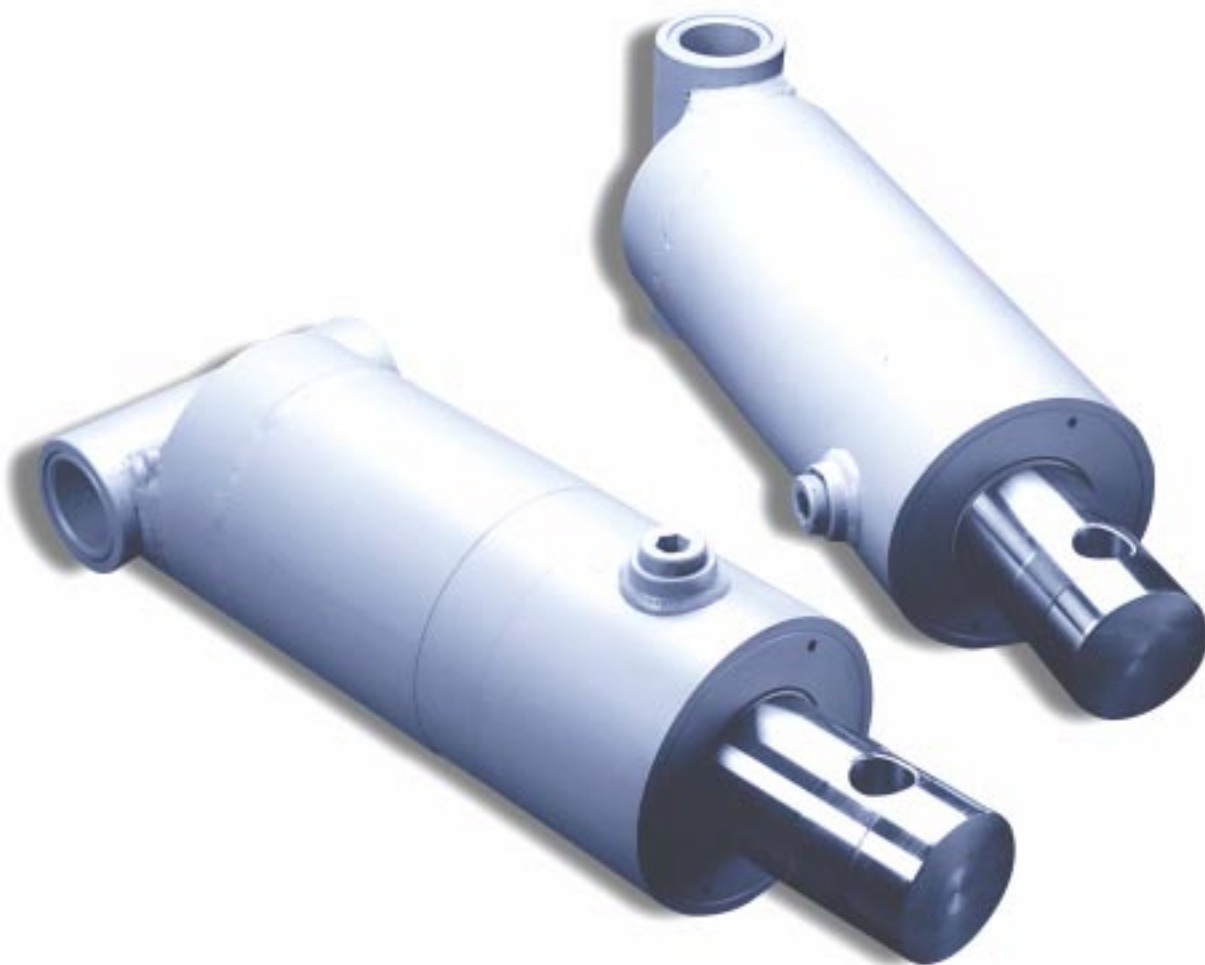

**VICKERS**<sup>®</sup>

# Table of Contents

Design Features and Specifications .....	2
How to Order.....	3
WH Mounting Dimensions.....	4
Rod End Styles .....	7
Technical Data .....	8

## Design Features and Specifications

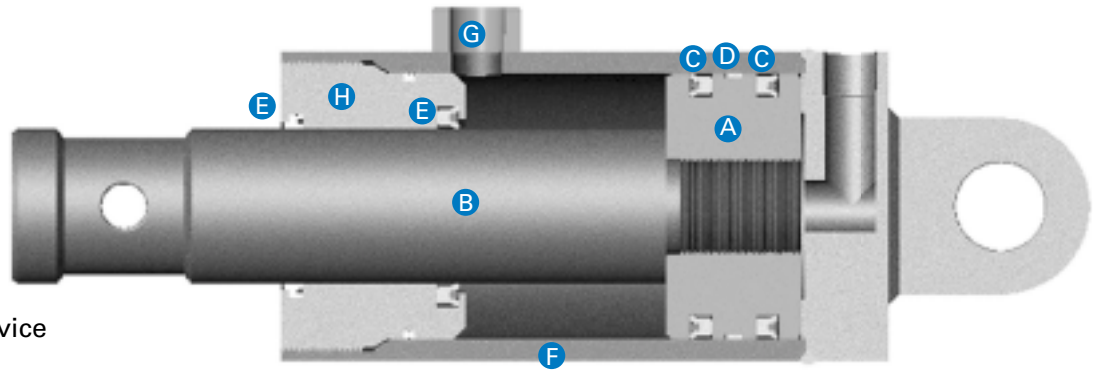

### Specifications

**Bore Sizes:** 4" - 12"

**Pressure Ratings:**

3,000 psi Hydraulic Service

#### **A** Piloted Ductile Iron Piston

- One-piece, ductile iron piston, piloted to ensure concentricity.
- Secured to the rod by threadlocker in bores up to 6" and set screws in 7" bores and up to insure a positive connection.

#### **B** Piston Rod

- Piston rod is machined from high yield, turned, ground and polished C-1045/50 microalloy steel.
- Piston Rods are hard chrome plated a minimum of .001" diametrically, to insure superior cylinder operation and life.
- Heavy plating, stainless steel, or chrome over nickel plating are available options.

#### **C** Piston Seals

- Specially designed, mechanically loaded piston seals minimize piston bypass.
- Bi-directional piston seal with outboard wear bands is standard on 9" and above.
- Bi-directional piston seal is optional for smaller bore sizes.

#### **D** Piston Wear Band

- Nonmetallic wear band provides side load protection.

#### **E** Rod Seal/Wiper

- Specially designed, high duro-meter, mechanically loaded rod seal virtually eliminates rod seal leakage.
- Urethane rod wiper is abrasion resistant and provides exclusion protection.

#### **F** High Yield Steel Tubing

- High yield strength steel tubing is produced to exceed the ASTM-513 specifications, and is hydraulically straightened before honing.
- This combination of superb base material and superior processing insures straight, smooth, and long life cylinders.

#### **G** Steel Port Boss

- Steel port boss insures a full thread, pressure-tight porting connection.

#### **H** Iron Rod Gland

- Standard gland is constructed of high strength ductile iron.
- Optional SAE 660 bronze material or wear bands are available to provide additional side load protection.
- All welded cylinders have a precision fit body seal and backup on the gland O.D.

# How to Order Series WH Cylinders

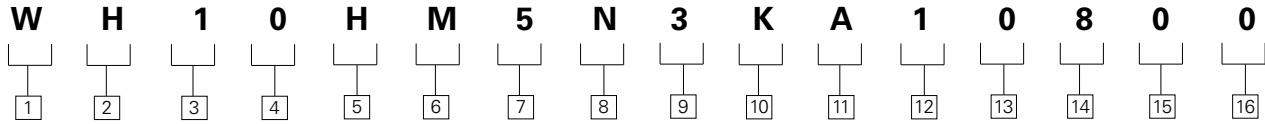

### 1 2 Series designation

WH – Welded Hydraulic Cylinder

### 3 4 Mounting Style

Code Mounting Style  
 08 – Head Flange  
 10 – Cap Clevis  
 47 – Cap Fixed Eye

### 5 6 Bore and Rod Diameter

Code	Bore	Rod
HL	4	1-3/4
HM	4	2
HP	4	2-1/2
KU	5	3
KV	5	3-1/2
LV	6	3-1/2
LW	6	4
MW	7	4
MZ	7	5
NZ	8	5
N1	8	5-1/2
R1	10	5-1/2
R4	10	7
S4	12	7
S7	12	9

### 7 Rod End Type

Code	Rod End Style
2	Short Female UN Thread
4	Full Male UN Thread
5	Small Male UN Thread
6	Plain-No Attachment
9	Intermediate Male UN Thread
G	Grooved End
K	Extended Small Male UN Thread
M	Extended Int. Male UN Thread
P	Pin Hole

### 8 Seals

Code	Application Type
N	Normal
L	Low Friction
T	High Temperature
D	Dirty/ Dusty Environment

### 9 Ports

Code	Port Style
1	NPTF
3	SAE/UN O-ring
6	SAE 4-bolt Manifold

### 10 Port Location

Ports are located as shown below when viewing cylinder from head end.  
 BF = Back Face center of cap

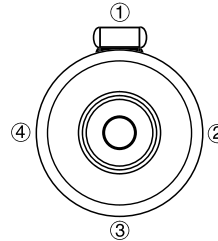

Code	Head	Cap
K	1	1
L	1	2
M	1	3
N	1	4
P	2	1
R	2	2
S	2	3
T	2	4
U	3	1
V	3	2
W	3	3
Y	3	4
1	4	1
2	4	2
3	4	3
4	4	4
5	1	BF
6	2	BF
7	3	BF
8	4	BF

### 11 Cushions

Code  
 A Noncushioned (both ends)

### 12 13 14 Cylinder Stroke

Items 12 & 13 indicate total cylinder stroke length from 00 through 99 inches.

Item 14 indicates fraction of an inch as follows:

Code	Fraction	Code	Fraction
0	0	8	1/2
1	1/16	9	9/16
2	1/8	A	5/8
3	3/16	B	11/16
4	1/4	C	3/4
5	5/16	D	13/16
6	3/8	E	7/8
7	7/16	F	15/16

### 15 16 Extra Rod Projection

("C" dimension)

Item 15 indicates inches from 0 through 9.

Item 16 indicates fractions of an inch per codes shown for item 14 above.

All dimensions in inches.

# Mounting Dimensions - WH08 Head Square Flange Mounts

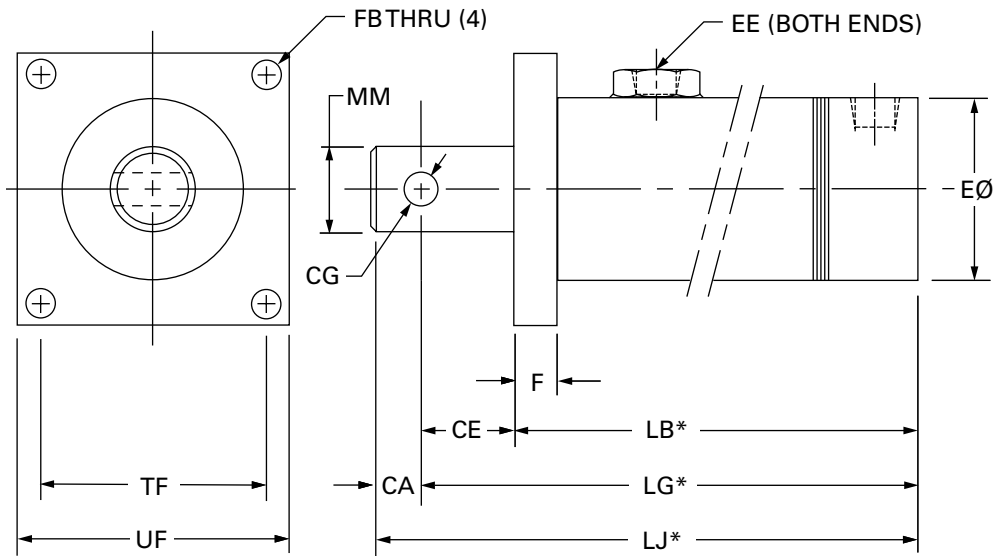

BORE SIZE	ROD DIA (MM)	CA	CE	CG	E	EE (NPTF)	EE (SAE)	F	FB	LB*	LG*	LJ*	TF	UF
4"	1.75	2.50	3.00	.75	4.62	.75	#12	.88	.56	6.25	9.25	11.75	6.38	7.62
4"	2	2.50	3.00	1.00	4.62	.75	#12	.88	.56	6.25	9.25	11.75	6.38	7.62
4"	2.5	2.50	3.00	1.00	4.62	.75	#12	.88	.56	6.25	9.25	11.75	6.38	7.62
5"	3	2.50	3.12	1.00	6.00	.75	#12	1.00	.81	7.50	10.62	13.12	10.00	12.00
5"	3.5	2.50	3.50	1.50	6.00	.75	#12	1.00	.81	7.50	11.00	13.75	10.00	12.00
6"	3.5	2.50	3.50	1.00	7.00	1.00	#16	1.50	.81	7.62	11.12	13.62	10.00	12.00
6"	4	2.50	3.50	1.50	7.00	1.00	#16	1.50	.81	8.12	11.62	14.12	10.00	12.00
7"	4	2.50	3.63	1.50	8.00	1.25	#20	1.50	1.03	9.00	12.88	15.38	14.25	18.00
7"	5	2.50	3.88	1.50	8.00	1.25	#20	1.50	1.03	9.00	12.88	15.38	14.25	18.00
8"	5	2.50	3.63	1.50	9.25	1.25	#20	2.50	1.03	10.50	14.12	16.62	14.25	18.00
8"	5.5	2.50	3.63	1.50	9.25	1.25	#20	2.50	1.03	10.50	14.12	16.62	14.25	18.00
10"	5.5	2.50	3.50	1.50	11.75	2.00	#32	3.50	1.81	14.44	17.94	20.44	18.38	22.00
10"	7	3.00	3.75	3.00	11.75	2.00	#32	3.50	1.81	14.69	18.44	21.44	18.38	22.00
12"	7	3.00	3.75	3.00	14.00	2.00	#32	3.50	2.06	15.63	19.38	22.38	18.38	22.00
12"	9	3.00	4.63	3.00	14.00	2.00	#32	3.50	2.06	15.63	20.25	23.25	18.38	22.00

Dimensions shown are mounting dimensions.

\* Add stroke to all starred dimensions.

NOTE: Rod sleeve available, specify I.D. x O.D. x Total Length

# Mounting Dimensions - WH10 Cap Clevis Mounts

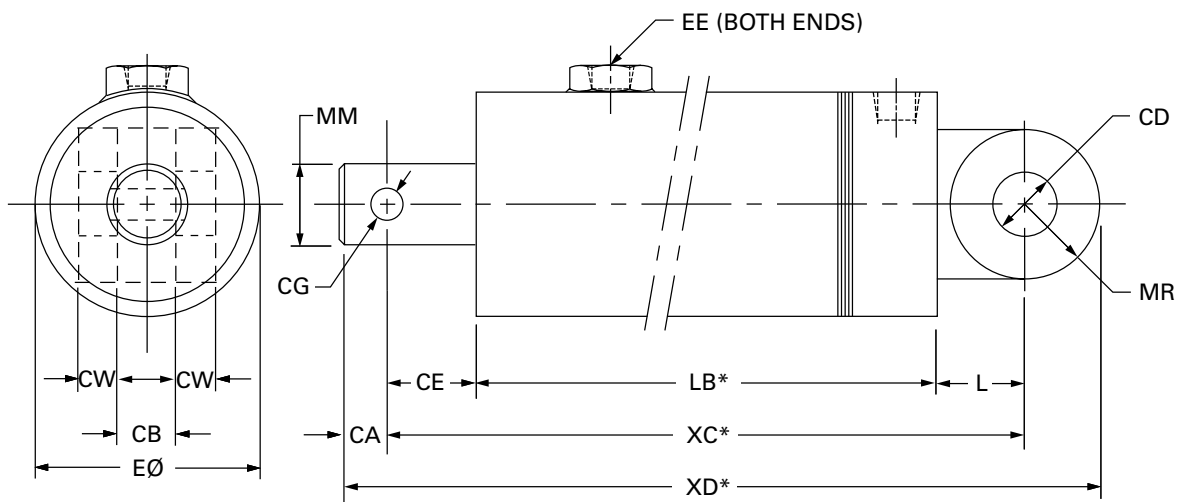

BORE SIZE	ROD DIA (MM)	CA	CB	CD	CE	CG	CW	E	EE (NPTF)	EE (SAE)	L	LB*	MR	XC*	XD*
4"	1.75	2.50	2.12	1.375	3.00	.75	1.00	4.63	.75	#12	1.88	6.25	1.38	11.12	15.00
4"	2	2.50	2.12	1.375	3.00	1.00	1.00	4.63	.75	#12	2.12	6.25	1.38	11.38	15.25
4"	2.5	2.50	2.12	1.375	3.00	1.00	1.00	4.63	.75	#12	2.00	6.25	1.38	11.38	15.25
5"	3	2.50	2.25	1.500	3.12	1.00	1.12	6.00	.75	#12	2.00	7.50	1.50	12.62	16.62
5"	3.5	2.50	2.25	1.500	3.50	1.50	1.12	6.00	.75	#12	2.25	7.50	1.50	13.25	17.25
6"	3.5	2.50	2.62	2.000	3.50	1.00	1.25	7.00	1.00	#16	2.50	7.62	2.00	13.62	18.12
6"	4	2.50	2.62	2.000	3.50	1.50	1.25	7.00	1.00	#16	2.50	8.12	2.00	14.12	18.62
7"	4	2.50	3.12	2.500	3.62	1.50	1.50	8.00	1.25	#20	3.12	9.00	2.50	16.00	21.00
7"	5	2.50	3.12	2.500	3.88	1.50	1.50	8.00	1.25	#20	3.12	9.00	2.50	16.00	21.00
8"	5	2.50	3.12	3.000	3.62	1.50	1.50	9.25	1.25	#20	2.88	10.50	3.00	17.00	22.50
8"	5.5	2.50	3.12	3.000	3.62	1.50	1.50	9.25	1.25	#20	2.88	10.50	3.00	17.00	22.50
10"	5.5	2.50	4.25	3.500	3.50	1.50	2.00	11.75	2.00	#32	4.00	14.44	3.50	21.94	27.94
10"	7	3.00	4.25	3.500	3.75	3.00	2.00	11.75	2.00	#32	4.00	14.69	3.50	22.44	28.94
12"	7	3.00	4.62	4.000	3.75	3.00	2.25	14.00	2.00	#32	4.50	15.62	4.00	23.88	30.88
12"	9	3.00	4.62	4.000	4.62	3.00	2.25	14.00	2.00	#32	6.19	15.62	4.00	26.44	33.44

Dimensions shown are mounting dimensions.

\* Add stroke to all starred dimensions.

NOTE: Rod sleeve available, specify I.D. x O.D. x Total Length

# Mounting Dimensions - WH47 Cap Eye Mounts

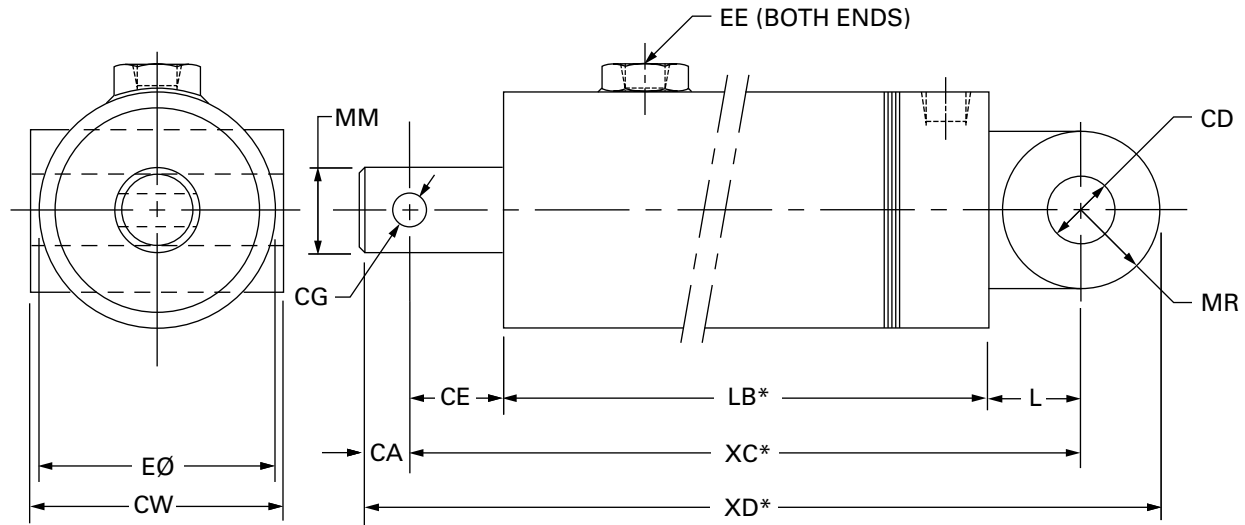

BORE SIZE	ROD DIA (MM)	CA	CD	CE	CG	CW	E	EE (NPT)	EE (SAE)	L	LB*	MR	XC*	XD*
4"	1.75	2.50	1.390	3.00	.75	5.00	4.63	.75	#12	1.19	6.25	1.19	10.44	14.13
4"	2	2.50	1.390	3.00	1.00	5.00	4.63	.75	#12	1.19	6.25	1.19	10.44	14.13
4"	2.5	2.50	1.390	3.00	1.00	5.00	4.63	.75	#12	1.19	6.25	1.19	10.44	14.13
5"	3	2.50	1.515	3.12	1.00	6.00	6.00	.75	#12	1.25	7.50	1.25	11.88	15.62
5"	3.5	2.50	1.515	3.50	1.50	6.00	6.00	.75	#12	1.25	7.50	1.25	12.25	16.00
6"	3.5	2.50	1.515	3.50	1.00	7.00	7.00	1.00	#16	1.25	7.50	1.25	12.38	16.12
6"	4	2.50	1.515	3.50	1.50	7.00	7.00	1.00	#16	1.25	8.12	1.25	12.88	16.62
7"	4	2.50	2.015	3.62	1.50	8.00	8.00	1.25	#20	1.88	9.00	1.88	14.50	18.88
7"	5	2.50	2.015	3.88	1.50	8.00	8.00	1.25	#20	1.88	9.00	1.88	14.75	19.12
8"	5	2.50	2.515	3.62	1.50	9.00	9.25	1.25	#20	2.25	10.50	2.25	16.38	21.12
8"	5.5	2.50	2.515	3.62	1.50	9.00	9.25	1.25	#20	2.25	10.50	2.25	16.38	21.12
10"	5.5	2.50	3.515	3.50	1.50	11.75	11.75	2.00	#32	2.75	14.44	2.75	20.69	25.94
10"	7	3.00	3.515	3.75	3.00	11.75	11.75	2.00	#32	2.75	14.69	2.75	21.19	26.94
12"	7	3.00	4.015	3.75	3.00	14.00	14.00	2.00	#32	3.00	15.62	3.00	22.38	28.38
12"	9	3.00	4.015	4.62	3.00	14.00	14.00	2.00	#32	3.00	15.62	3.00	23.25	29.25

Dimensions shown are mounting dimensions.

\* Add stroke to all starred dimensions.

NOTE: Rod sleeve available, specify I.D. x O.D. x Total Length

# Series WH Rod End Selection

**Rod End Style 2**

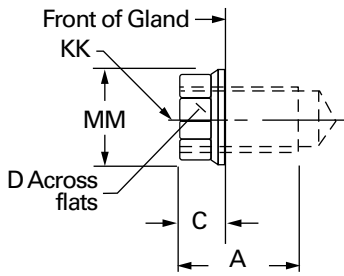

**Rod End Style 4**

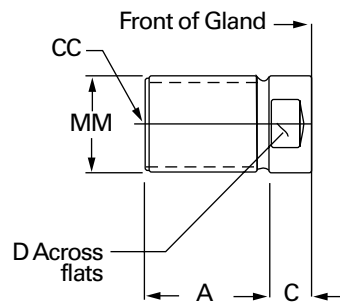

**Rod End Style 5**

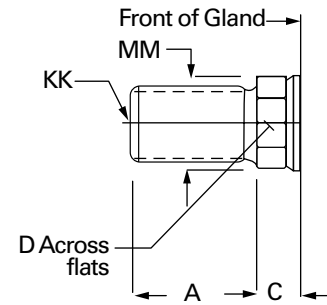

**Rod End Style 6**

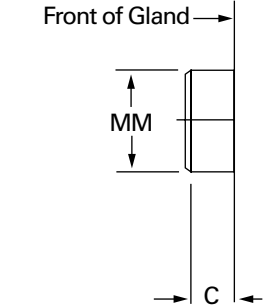

**Rod End Style 9**

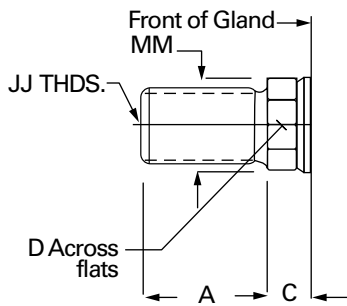

**Rod End Style G**

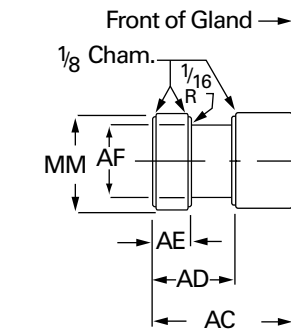

**Rod End Style K**

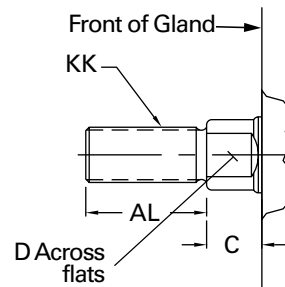

**Rod End Style M**

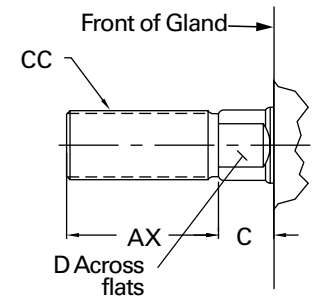

ROD DIA. (MM)	A	C	D	CC THREAD	JJ THREAD	KK THREAD	AC	AD	AE	AF	AL	AX
1.75	2.00	.75	1.50	1.750-12	1.500-12	1.250-12	1.75	1.31	.50	1.13	2.75	3.12
2	2.25	.88	1.69	2.000-12	1.750-12	1.500-12	2.63	1.69	.63	1.38	3.12	4.12
2.5	3.00	1.00	2.06	2.500-12	2.250-12	1.875-12	3.25	1.94	.75	1.75	4.12	4.75
3	3.50	1.00	2.63	3.000-12	2.750-12	2.250-12	3.63	2.44	.88	2.25	4.75	5.50
3.5	3.50	1.00	3.00	3.500-12	3.250-12	2.500-12	4.38	2.69	1.00	2.50	5.00	6.38
4	4.00	1.00	3.38	4.000-12	3.750-12	3.000-12	4.50	2.69	1.00	3.00	5.62	6.56
5	5.00	1.00	4.25	5.000-12	4.750-12	3.500-12	5.38	3.19	1.50	3.88	7.00	7.56
5.5	5.50	1.00	4.63	5.500-12	5.250-12	4.000-12	6.25	3.94	1.88	4.38	7.75	9.56
7	7.00	1.00	6.00	7.000-12	6.500-12	5.500-12	6.50	4.06	2.00	5.75	10.00	10.50
9	9.00	1.00	8.00	9.000-12	8.500-12	6.500-12	6.75	4.13	2.00	7.25	12.50	13.50

All dimensions in inches

\*NOTE: For Rod End Pin Hole dimensions, see cylinder mounting dimension drawings on pages 4-6.

# Technical Data - Rod Size and Stop Tube Selection

## Rod Size Selection

Standard rod sizes are normally suitable for all applications except for long stroke or high thrust applications. Proper selection of minimum rod size may be determined by the following steps:

1. With knowledge of bore size and operating pressure, thrust (T) may be determined. Refer to the graph in the next column.
2. Select from illustrations to the right the type of mounting to be used and determine the length of L with the piston rod in the fully extended position.
3. Find the value of L at the bottom of the graph and follow its line vertically until it intercepts the horizontal line representing the maximum push thrust that will be applied to your cylinder. The intersection of these two lines will fall within a stripe representing the minimum recommended piston rod diameter for your application.

## Stop Tubes

Stop tubes are located between the piston and the rod shoulder on the head end of the cylinder. Bearing loading is reduced by separating the piston and the rod bushing. Bearing wear and tendency to buckle is reduced.

To determine if a stop tube is required and the length of stop tube needed, use the following procedure:

Determine the value of L with the piston rod in the fully extended position. If the value of L is under 40 inches, no stop tube is needed. If L is greater than 40 inches, one inch of stop tube is recommended for each 10 inches or fraction thereof beyond 40.

**Special note: When specifying stroke and stop tube lengths, please include net working stroke plus the stop tube length.**

## Firmly Guided Rod End

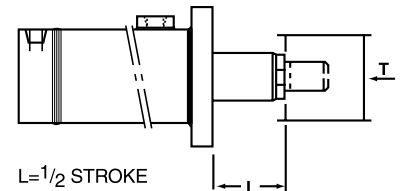

## Supported Rod End

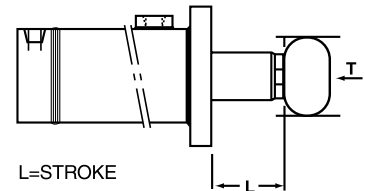

## Unsupported Rod End

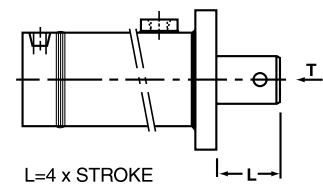

## Clevis Mount

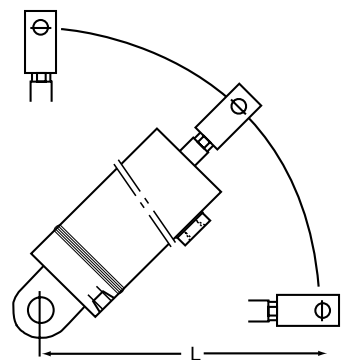

# Stop Tube Graph

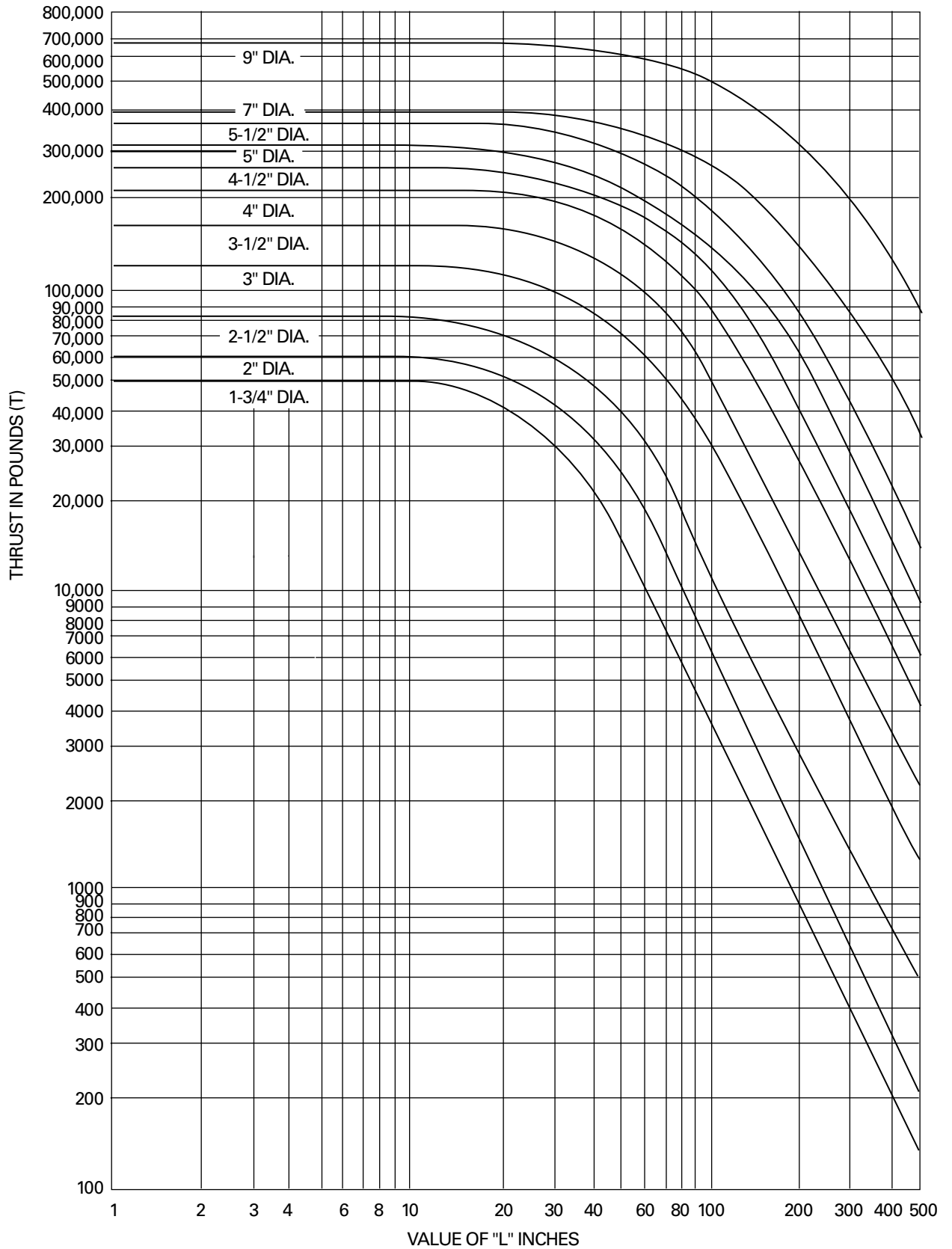

# Notes

# Notes

**Eaton**  
14615 Lone Oak Road  
Eden Prairie, MN 55344  
USA  
Tel: 952 937-9800  
Fax: 952 974-7722  
[www.hydraulics.eaton.com](http://www.hydraulics.eaton.com)

**Eaton**  
1112 Brooks Street, S.E.  
Decatur, AL 35601  
Tel: 256 350-2339  
Fax: 256 351-1264

**Eaton**  
2425 W. Michigan Avenue  
Jackson, MI 49202  
Tel: 517 787-7220  
Fax: 517 787 3450

**Eaton**  
7638 Pacific Avenue  
White City, OR 97503-1091  
Tel: 541 826-2131  
Fax: 541 826-3344

**VICKERS**<sup>®</sup>

**EATON**

**Vickers**

© 2003 Eaton Corporation  
All Rights Reserved  
Printed in USA  
Document No. V-CC-MC-0002-E  
June 2003