



MF2P Series Filters

Flows to 113.5 L/min
(30 USgpm)

Pressures to 275.5 bar
(4000 PSI)



Features and Benefits

- Designed to comply with ANSI specifications and ISO cleanliness standards.
- Visual, electrical, and electrical indicators with lamp options for system design flexibility.
- Fully serviceable without tools.
- Zero leak by-pass valve construction.
- Wide range of element lengths for maximum design flexibility.
- High efficiency replacement elements in standard configurations (C-Pak) to meet Target Cleanliness Levels.
- High collapse elements available for non-bypass applications.

DESIGN SPECIFICATIONS

Rated flow:	Length 5 Length 7	68 L/min (18 USgpm) 113.5 L/min (30 USgpm)
Housing & Element Compatibility:	Compatible with most petroleum oil, oil-in-water and water-in-oil fluids. Optional seals available for phosphate esters.	
Temp range:	-26°C to +121°C (-15°F to +250°F)	
Pressure rating:	Operating Proof Burst Fatigue	276 bar (4000 PSI) 414 bar (6000 PSI) 980 bar (14,210 PSI) 276 bar (4000 PSI)
Material:	Head Bowl	Ductile iron Steel
Dry weight: (Approximate)	Length 5 Length 7	3.9 kg (8.3 lbs) 4.5 kg (9.9 lbs)



Dimensions

MF2P Housing

mm (inch)

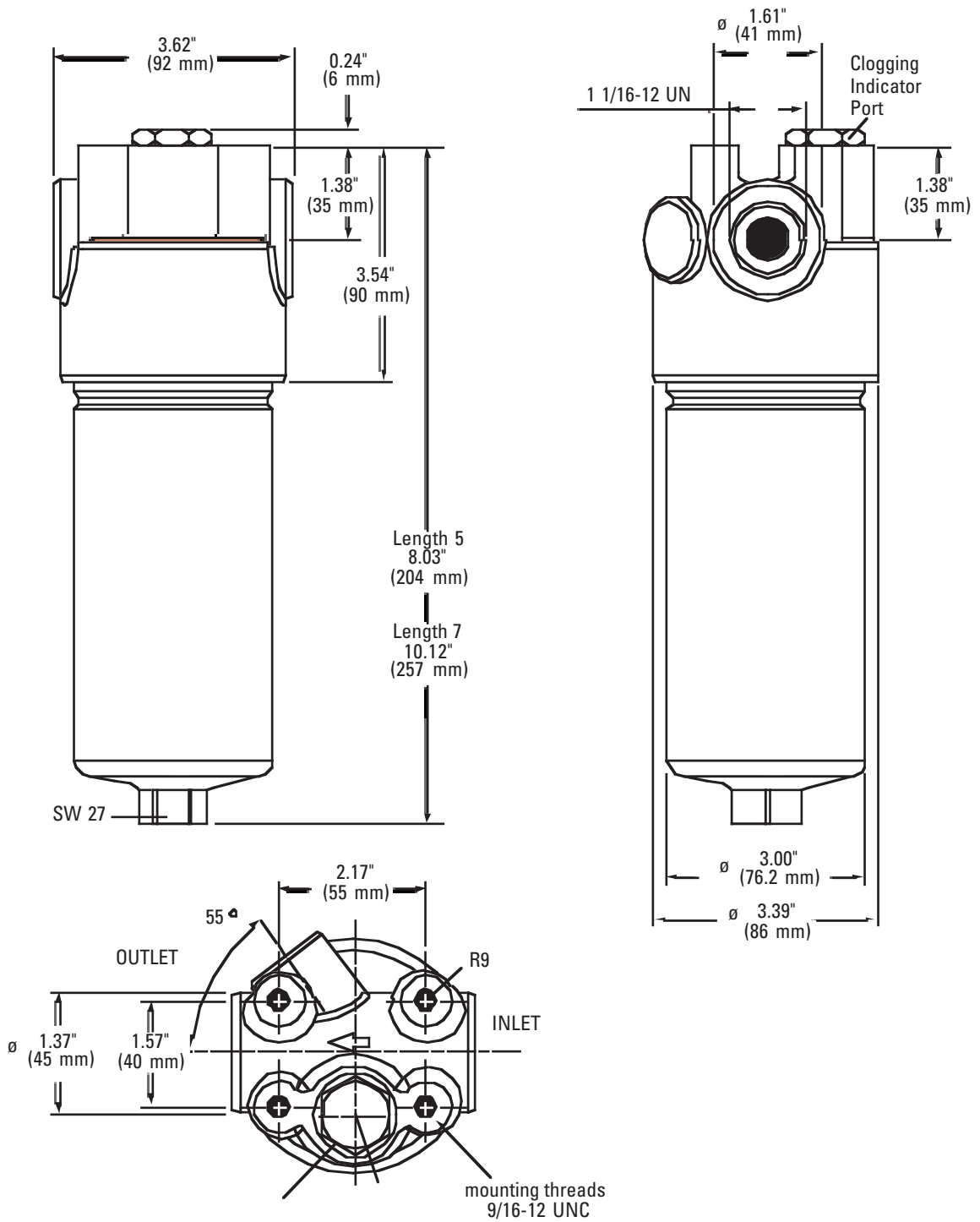

Model Codes

MF2P Series Filter Assembly Model Code

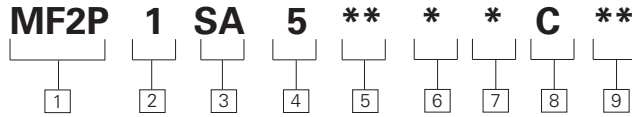

Sample model code:
MF2P-1-SA-5-UN-B-5-C-05

<p>1 Filter Series MF2P</p> <p>2 Element Collapse Rating 1 - 250 PSI Low Collapse</p> <p>3 Port options SA - 1.062 - 12UN SAE-12 (3/4" tube)</p> <p>4 Valve options 5 - Bypass set at 100 PSI (7 bar) cracking pressure</p> <p>5 Indicator options First Designator - Indicator Type A - Visual 70 PSI J - No Indicator (plug) U - Electrical 70 PSI</p>	<p>Second Designator - Electrical Receptical B - Brad Harrison H - Hirshman J - Hirshman with 24 volt light K - Hirshman with 115 volt light L - Hirshman with 230 volt light N - No Connector - use with visual indicators and "J"</p> <p>6 Seal material B - Buna-N V - Viton-A <small>Viton is a registered trademark of E.I. DuPont</small></p> <p>7 Element length Assembly length 5 - 117mm (5") 210mm (8.27") 7 - 169mm (7") 263mm (10.36")</p>	<p>8 Element construction C - 250 PSI Low Collapse</p> <p>9 Fluid cleanliness rating</p> <table border="0"> <thead> <tr> <th>Code</th> <th>Target fluid cleanliness level</th> </tr> </thead> <tbody> <tr> <td>03</td> <td>16/14/12 or better</td> </tr> <tr> <td>05</td> <td>18/16/14 or better</td> </tr> <tr> <td>10</td> <td>20/18/15 or better</td> </tr> <tr> <td>20</td> <td>22/19/16 or better</td> </tr> </tbody> </table> <p>The table assumes limited ingress/single pass of pump flow through element. For detailed assistance, see "The Systemic Approach to Contamination Control" or contact your local Eaton representative.</p>	Code	Target fluid cleanliness level	03	16/14/12 or better	05	18/16/14 or better	10	20/18/15 or better	20	22/19/16 or better
Code	Target fluid cleanliness level											
03	16/14/12 or better											
05	18/16/14 or better											
10	20/18/15 or better											
20	22/19/16 or better											

V0512 Series Replacement Element Model Codes

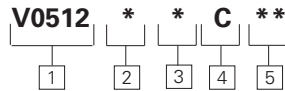

Sample model code:
V0512-B-5-C-05

<p>1 Filter element V0512 - For use with MF2P series housings</p> <p>2 Seal material B - Buna-N V - Viton-A <small>Viton is a registered trademark of E.I. DuPont</small></p> <p>3 Element length mm (inch) 5 - 117 (5) 7 - 169 (7)</p>	<p>4 Element construction C - C-Pak (grade 3, 5, 10, 20)</p> <p>5 Fluid cleanliness ratings</p> <table border="0"> <thead> <tr> <th>Code</th> <th>Target fluid cleanliness level</th> </tr> </thead> <tbody> <tr> <td>03</td> <td>16/14/12 or better</td> </tr> <tr> <td>05</td> <td>18/16/14 or better</td> </tr> <tr> <td>10</td> <td>20/18/15 or better</td> </tr> <tr> <td>20</td> <td>22/19/16 or better</td> </tr> </tbody> </table>	Code	Target fluid cleanliness level	03	16/14/12 or better	05	18/16/14 or better	10	20/18/15 or better	20	22/19/16 or better	<p>The table assumes limited ingress/single pass of pump flow through element. For detailed assistance, see "The Systemic Approach to Contamination Control" or contact your local Eaton representative.</p>
Code	Target fluid cleanliness level											
03	16/14/12 or better											
05	18/16/14 or better											
10	20/18/15 or better											
20	22/19/16 or better											

M2P SERIES DESIGN SPECIFICATIONS

Rated flow:	Length 5 Length 7	68 L/min (18 USgpm) 280 L/min (74 USgpm)
Housing & Element Compatibility:	Compatible with most petroleum oil, oil-in-water and water-in-oil fluids. Optional seals available for phosphate esters.	
Temp range:	-25°C to +120°C (-15°F to +250°F)	
Construction:	C-Pak	

MF2P Series Flow Data

Flow versus pressure drop:
150 SUS (32 cSt) oil with
specific gravity of <0.9

mm (inch)

Housing Curves

**Differential Pressure Versus Flow
MF2P (SAE 12 Porting)**

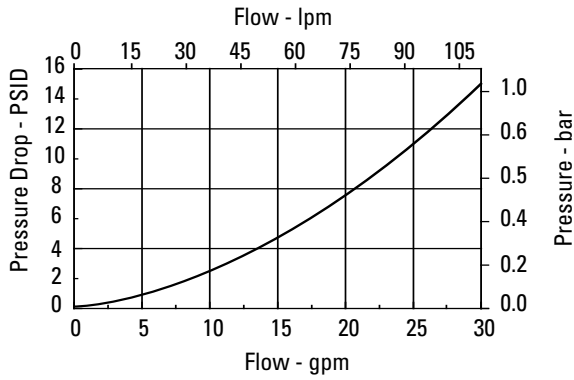

Element Flow Curves

MF2P-5

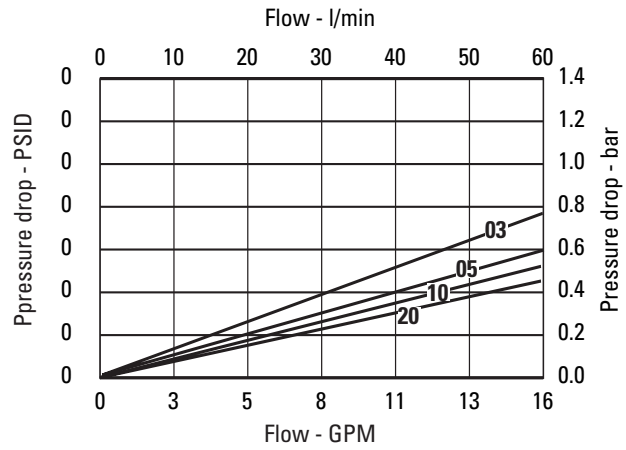

MF2P-7

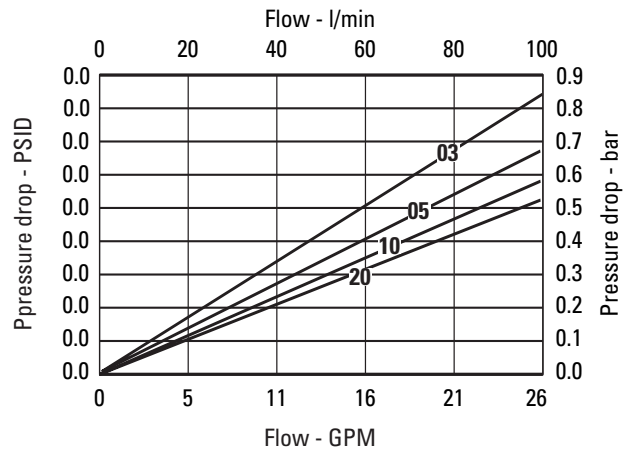

Eaton
14615 Lone Oak Road
Eden Prairie, MN 55344
USA
Tel: 952 937-9800
Fax: 952 974-7722
www.hydraulics.eaton.com

Eaton
20 Rosamond Road
Footscray
Victoria 3011
Australia
Tel: (61) 3 9319 8222
Fax: (61) 3 9318 5714

Eaton
Eaton Fluid Power GmbH
Dr.-Reckeweg-Str. 1
D-76532 Baden-Baden, Germany
Tel: +49 (0) 7221 682-0
Fax: +49 (0) 7221 682-788

