

## HF3P Series High Performance Filter

Flows to 570 L/min (150 USgpm)

Service Data

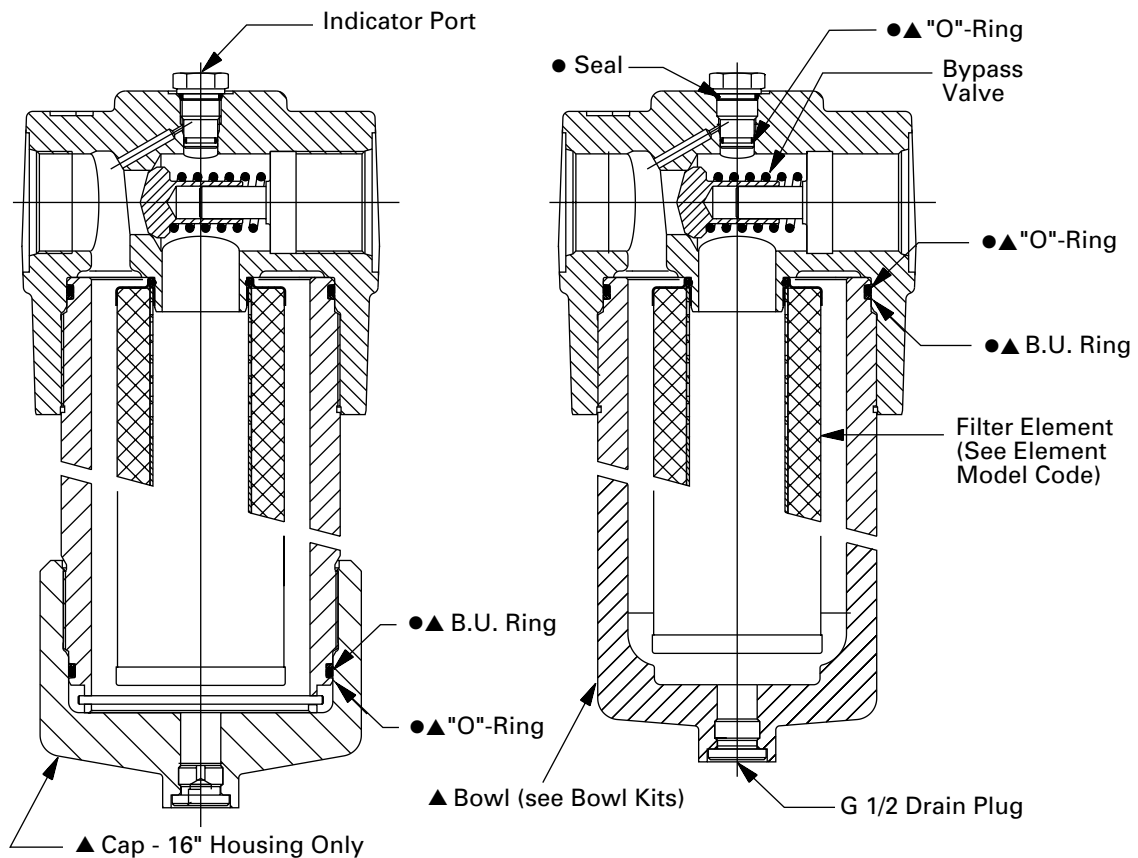

● Included in Seal Kits

**SEAL KIT PRODUCT NUMBERS**

3039696 Buna

3039697 Viton\*

\* Viton is a registered trademark of E.I. DuPont

▲ Included in Bowl Kits

**BOWL KIT PRODUCT NUMBERS**

3039672 Buna 4"

3039684 Viton 4"

3039673 Buna 8"

3039685 Viton 8"

3039674 Buna 13"

3039686 Viton 13"

3039675 Buna 16"

3039687 Viton 16"

# Model Code

## Housing Assembly

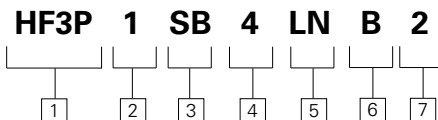

### 1 Filter Series

#### HF3P

### 2 Element Collapse

#### Rating

- 1 - 150 PSI Low Collapse
- 4 - 3000 PSI High Collapse

### 3 Port Options

- BB** - G1 to ISO 228
- BD** - G11/2 to ISO 228
- ME** - 1 1/2" SAE 4 bolt Flange  
Code 61 (M12 x 1.75)
- MJ** - 2" SAE 4 bolt Flange  
Code 61 (M12 x 1.75)
- MU** - 2" SAE 4 bolt Flange  
Code 62 (M20 x 2.5)
- SB** - 1.312 - 12 UN SAE-16  
str. Thd. (1" tube)
- SD** - 1.875 - 12 UN SAE-24  
str. Thd. (1 1/2" tube)

### Port Options (continued)

- FE** - 1 1/2" SAE 4 bolt Flange  
Code 61 (UNC)
- FJ** - 2" SAE 4 bolt Flange  
Code 61 (UNC)
- FU** - 2" SAE 4 bolt Flange  
Code 62 (UNC)

### 4 Valve options

- 1 - Non-Bypass
- 4 - Bypass set at 43 PSI  
cracking pressure
- 6 - Bypass set at 90 PSI  
cracking pressure
- 8 - Reverse Flow Valve  
Non-Bypass
- 9 - Reverse Flow Valve 43  
PSI Bypass

### 5 Indicator options

#### First Designator - Indicator Type

- A** - Visual 70 PSI
- J** - No Indicator (plug)
- K** - Visual 15 PSI
- L** - Visual 30 PSI
- O** - Visual 115 PSI
- R** - Electrical 30 PSI
- T** - Electrical 115 PSI
- U** - Electrical 70 PSI

#### Second Designator - Electrical Receptical

- B** - Brad Harrison
- H** - Hirshman
- J** - Hirshman  
with 24 volt light
- K** - Hirshman  
with 115 volt light

### L - Hirshman

with 230 volt light

**N** - No Connector - use with  
visual indicators and "J"

### 6 Seal material

- B** - Buna-N
- V** - Viton-A

### 7 Element length

Element length	Assembly length
mm (in)	mm (in)
1 - 101 (4)	230 (9.1)
2 - 203 (8)	293 (11.5)
4 - 330 (13)	413.7 (16.3)
5 - 406 (16)	569 (22.4)

## Element

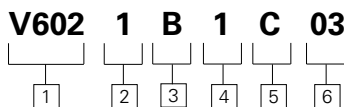

### 1 Filter element

**V602** - For use with HF3P,  
HF3PS and OFR30  
series filters

### 2 Element collapse rating

- 1 - 10 bar (150 PSI)  
Low Collapse
- 4 - 210 bar (3000 PSI)  
High Collapse

NOTE:

Use **1** only with bypass valve.

### 3 Seal material

- B** - Buna-N
- V** - Viton-A

### 4 Element length

- mm (inch)
  - 1 - 101 (4)
  - 2 - 203 (8)\*
  - 4 - 330 (13)
  - 5 - 406 (16)
- \*HF3

### 5 Element construction

- C** - C-Pak (grade 3, 5, 10, 20)
- H** - H-Pak (grade 3, 5, 10)

### 6 Fluid cleanliness ratings

Code	Fluid cleanliness
<b>03</b>	16/ <b>14</b> / <b>12</b> or better
<b>05</b>	18/ <b>16</b> / <b>14</b> or better
<b>10</b>	20/ <b>18</b> / <b>15</b> or better
<b>20</b>	22/ <b>19</b> / <b>16</b> or better

The table assumes limited  
ingression/single pass of  
pump flow through element.  
For detailed assistance, see  
"The Vickers Guide to  
Systemic Contamination  
Control" or contact your local  
Eaton representative.

# Model Code

## Indicator

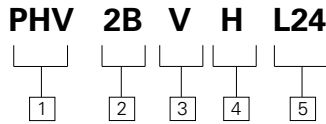

**1 Indicator type and pressure rating**

**PHV** - visual 420 bar (6000PSI)  
**PHE** - electrical 420 bar (6000PSI)

**2 Pressure setting**

**2B** - 2 bar (30PSID)  
**5B** - 5 bar (75PSID)  
**8B** - 8 bar (115PSID)

**3 Seal material**

**V** - Viton-A

**4 Connector**

**B** - Brad Harrison 5 Pin  
**H** - Hirshman  
**N** - None (use with PV indicators)

**5 Light Option**

**L24** - 24 Volt Lamp  
**L115** - 115 Volt Lamp  
**L230** - 230 Volt Lamp (Use with Hirshman Connector only)

## Schematic Wiring Diagram

### Indicator Switch

**Note**

When fitting indicator, torque to 41-47 Nm.

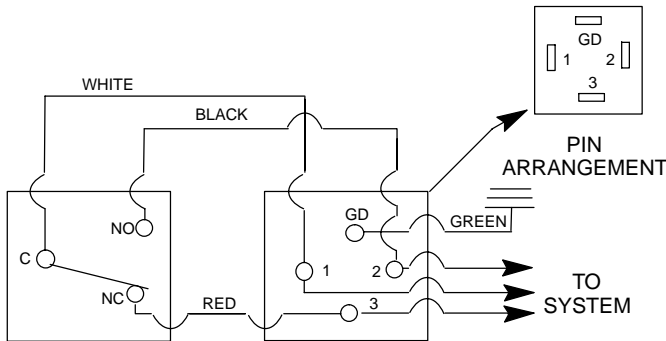

Hirschmann (DIN 43650 Type AM) Receptacle

### Electrical

Switch: SPDT  
 Rating: 7 amps, resistive  
 4 amps, inductive  
 2 amps, lamp load  
 @28 VDC, 115 VAC 60 Hz &  
 220 VAC 50 Hz or 60 Hz

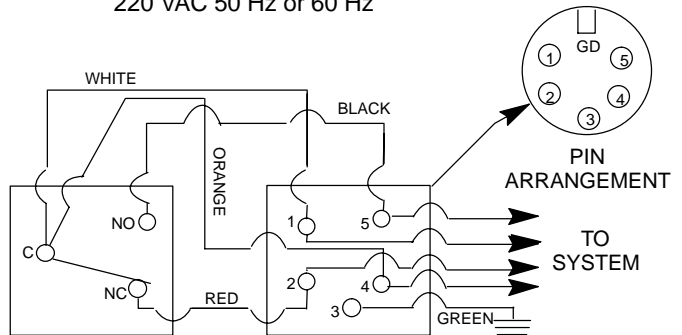

Brad Harrison (41512) Receptacle

**Eaton**  
 14615 Lone Oak Road  
 Eden Prairie, MN 55344  
 USA  
 Tel: 952 937-9800  
 Fax: 952 974-7722  
 www.hydraulics.eaton.com

**Eaton**  
 20 Rosamond Road  
 Footscray  
 Victoria 3011  
 Australia  
 Tel: (61) 3 9319 8222  
 Fax: (61) 3 9318 5714

**Eaton**  
 46 New Lane, Havant  
 Hampshire PO9 2NB  
 England  
 Tel: (44) 23 92 486 451  
 Fax: (44) 23 92 487 110

