

STC® Direct Port Tool Instructions

Technical Data

Model FT-1362

Model FT-1363

Model FT-1364

STC® O-ring/Backup Ring Insertion Tool–FT1362

Getting Started

For longest tool life it is recommended to operate the tool at the lowest pressure to do the job. The tool has a **maximum air pressure** of 100 psi.

Tool must be lubricated; either with an in-line oiler located no more than 6ft from the tool or oiled directly through the rear of the power pack with several drops of good hydraulic oil weekly.

Insertion tool must be cleaned and foreign material removed weekly or more often if necessary.

Always wear eye and ear protection when operating this tool.

Operating Instructions

1. Hold the unit in either hand as shown in Figure 1. Place the tool in the palm of the hand with the thumb comfortably resting on the actuation lever. The tool is designed for both left and right handed operation.

2. Place o-ring and backup ring together in the groove with the free hand and gently squeeze at the side to secure in place (Figure 2). The o-ring must be on the side caught by the hook loop.

3. While still holding the o-ring and backup ring, press the actuation lever to retract the hook and load the components (Figure 3). If one or both of

the components does not load properly, release the actuator, discard the components and try again with new components.

CAUTION



Never Place Fingers On The Tool Hook Or In Its Path While The Tool Is Plugged Into An Air Supply!

Personal Injury Can Occur!

4. Insert the loaded device into the part to be assembled (Figure 4). The face of the tool must be held firmly to the part being assembled.

5. While holding firmly in place, release the actuation lever of the tool.

6. Gently pull the device from the part. If the device resists, then twist the tool gently while pulling.

7. Inspect part to see that components were installed properly and that the o-ring and backup ring were not damaged or deformed during the process (Figure 5).

Repeat steps 1-7 for additional assemblies.



Figure 1 – Holding the Insertion Tool

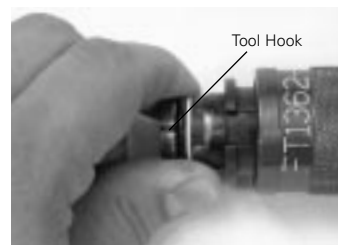

Figure 2 – Squeezing the O-ring & Backup Ring

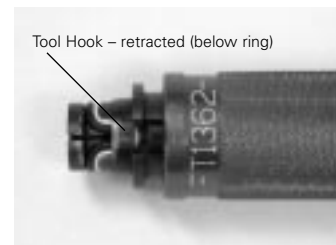

Figure 3 – O-ring & B-ring Loaded Into Tool

CAUTION



Tooling Under Pressure! Always Disconnect Air Supply Before Working On Tool.

Personal Injury Can Occur!

Replacing The Hook

- Refer to assembly print #: FT1362

1. Unthread the adapter (Item 3) counterclockwise and pull off part. Be sure that the pusher (Item 4) does not fall out.

2. Slide the pusher off the collar (Item 2).

3. Use a straight-shafted device to press the roll pin (Item 5) out of the pusher.

4. Pull the hook (Item 6) from the bottom of the pusher.

5. Insert the new hook.

6. Gently press the roll pin in so that it is centered in the pusher

7. Place the pusher back onto the collar.

8. Align the pusher assembly with the channel assembly and thread the adapter back on to the pneumatic actuator.

Troubleshooting

Hook will not retract when you push the lever.

- Check the air pressure
- The internal slide assembly may be gummed up. Take apart as outlined in the "Replacing The Hook" section and clean with a solvent.

Tool is difficult to remove after inserting components.

- Are the components being installed in the correct orientation? The o-ring should be on the bottom and the backup ring on the top when looking down into the finished part (Figure 6).

Is the hook cutting or tearing the components? It may need replacing.

If the backup ring is not going all the way into the gland, the pusher may need to be cleaned or replaced.

Check to see that when the components are loaded and

the tool is retracted (Figure 3) that the backup ring is behind the o-ring and not underneath it at the tip of the hook. If this is the case then:

- Do you have the right components?
- Make sure that when you are loading it that you are squeezing the o-ring and backup ring sufficiently.
- Check to see if the hook is damaged or broken. If so then replace the hook.

The channel location is out of alignment.

- Loosen the Adapter by hand (Item 3) by turning it counter-clockwise approximately 1/4 turn.
- Turn the channel to the desired location.
- Hand-tighten the Adapter Clockwise.



Figure 4 – Place The Tool Inside The Part



Figure 5 – Properly Assembled O-ring & B-ring

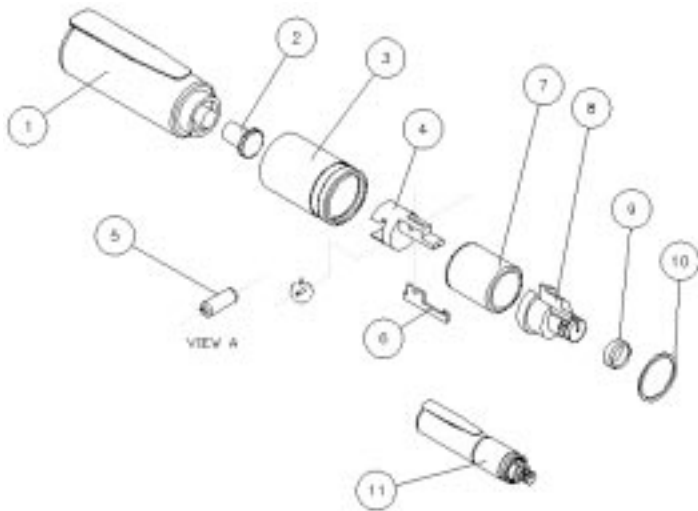

STC Portable Insertion Tool-Parts List

Item	Description	Part Number	Vendor	QTY
1	Pneumatic Actuator	SP-001-RV	Simonds	1
2	Coupler	FT1362-02	Lomar	1
3	Aluminum adapter	FT1362-SIZE-05	Lomar	1
4	O ring Pusher	FT1362-SIZE-03	Lomar	1
5	3/32 x 1/4 Roll Pin	*	*	1
6	Component Hook	FT1362-SIZE-07	Lomar	1
7	Bronze Sleeve	6391K285	McMaster-Carr	1
8	Guide Chorinal	FT1362-SIZE-04	Lomar	1
9	Guide Sleeve	FT1362-06-08	Lomar	1
10	Spiral Ring	WH-125	Smalley Steel Ring Co1	1
11	STC O ring Insertion	SIZE	Eaton	1

STC® Retaining Ring Insertion Tool–FT1363

Getting Started

Insert the holding bar, #FT1363-01-SIZE, into the handle grips, #FT1363-03, as shown in Figure 1.

Insert the tool head, #FT1363-02-SIZE, into the holding bar, as shown in Figure 2, and tighten socket set screw.



Figure 1



Figure 2

Operating Instructions

1. Hold the unit in either hand as shown in Figure 3.
2. Place the retaining ring on top of the part as shown in Figure 4.
3. Insert the end of the tool head over top of the retaining ring as shown in Figure 5.
4. Rotate the tool in a circular motion while applying a downward force and pivoting around

the retaining ring as shown in Figure 6.

5. Once the retaining ring has snapped into the appropriate groove, remove tool from part.
 6. Inspect part to ensure that retaining ring was installed properly as shown in Figure 7.
- Repeat steps 1-6 for additional assemblies.



Figure 3

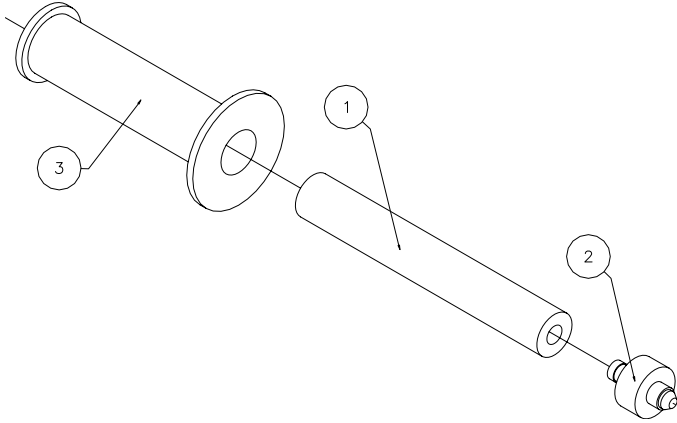

STC Retaining Ring Insertion Tool-Parts List

ITEM	DESCRIPTION	PART NUMBER	QTY
1	Holding Bar	FT1363-01-SIZE	1
2	Tool Head	FT1363-02-SIZE	1
3	Handle Grip	FT1363-03	1



Figure 4



Figure 5



Figure 6



Figure 7

STC® Retaining Ring Test Tool-FT1364

Getting Started

For longest tool life it is recommended to operate the tool at the lowest pressure to do the job. The tool has a **maximum air pressure** of 100 psi.

Operating Instructions

1. Hold the latch test tooling in either hand as shown in Figure 1.
2. Load male end of latch test tooling into female end of part (Figure 2).
3. Press and hold the actuation lever to perform the test.
4. While holding the actuation lever, try to separate the part and the latch test tooling to

Tool must be lubricated; either with an in-line oiler located no more than 6ft from the tool or oiled directly through the rear of the power pack with several drops of good hydraulic oil weekly.

Insertion tool must be cleaned and foreign material removed weekly or more often if necessary.

Always wear eye and ear protection when operating this tool.

ensure the latch has been installed properly

- If latch fails, remove part and release actuation lever. Skip to step 9.
- If latch test passes, release the actuation lever.

5. Turn the outer aluminum casing as far clockwise as possible (Figure 3).

6. Press and hold the actuation lever and pull latch test tooling from part.

7. Release the actuation lever and the outer aluminum casing, allowing it to return to the original position.

Repeat steps 1-7 for additional latch tests.



Figure 1 – Holding Tool



Figure 2 – Loading Tool Into Part



Figure 3 – Twisting Tool To Release

CAUTION



Tooling Under Pressure! Always Disconnect Air Supply Before Working on Tool. Personal Injury Can Occur!

Troubleshooting

Mandrel will not retract when you push the actuation lever.

- Check the air pressure.
- The internal assembly may be gummed up. Take apart and clean with a solvent. Then reassemble tooling as outlined in the ASSEMBLY INSTRUCTIONS.

Tool is difficult to remove after testing the component.

- While holding the actuation lever to release the part, push the latch test tooling further into the part and then pull the tester out from the part.

Outer aluminum casing does not return to original position after turning clockwise.

- Spring(s) may be damaged. Disassemble tool and examine springs. Replace damaged spring(s).
- Tool may be damaged or worn. Inspect tool for damage and replace parts as necessary.

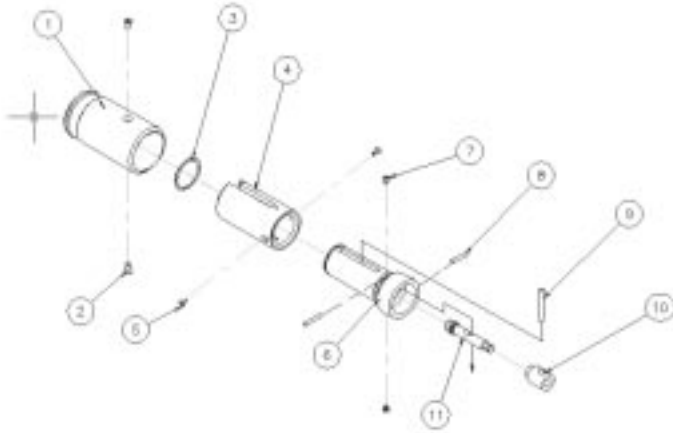

STC Retaining Ring Test Tool-Parts List

Item	Description	Part Number	QTY
1	Aluminum Casing	FT-1364-SIZE-05	1
2	6-32x1/4" Flat Head Screw	*	1
3	Retaining Ring	FT-1364-SIZE-07	1
4	Inner Sleeve	FT-1364-SIZE-06	1
5	4-40x1/4" Flat Head Screw	*	1
6	Guide	FT-1364-SIZE-04	1
7	4-40x1/8" Cap Screw	*	1
8	Compression Spring	FT-1364-03	1
9	3/16" x 1-1/4" Dowel Pin	*	1
10	Release	FT-1364-SIZE-03	1
11	Mandrel	FFT-1364-SIZE-02	1

Eaton
14615 Lone Oak Road
Eden Prairie, MN 55344
USA
Tel: 952 937-7254
Fax: 952 974-7130
www.hydraulics.eaton.com

Eaton
20 Rosamond Road
Footscray
Victoria 3011
Australia
Tel: (61) 3 9319 8222
Fax: (61) 3 9318 5714

Eaton
46 New Lane, Havant
Hampshire PO9 2NB
England
Tel: (44) 23 92 486 451
Fax: (44) 23 92 487 110